

# DELKIN DEVICES®

## Embedded USB Module Engineering Specification

Document Number: L5ENG00291  
Revision: 1.9



No part of this document may be reproduced, stored in a retrieval system, or transmitted in any form or by any means, mechanical, electronically, chemical, manual, recorded or otherwise without written permission of Delkin Devices. This document is for information use only and is subject to change without prior notice. Delkin Devices assumes no responsibility for any errors that may appear in this document.

**General Description**

The Delkin Embedded USB Module provides up to 32 GB of available storage, in an easily integrated module, perfect for embedded computing applications. The Delkin Embedded USB 2.0 Embedded Module can be configured as a removable or fixed drive, allowing its use as for data storage or as a bootable disk drive.

**Features**

- Available in the following capacities:
  - SLC: 128MB, 256MB, 512MB, 1GB, 2GB, 4GB, 8 GB and 16GB
  - MLC: 2GB, 4GB, 8 GB, 16GB and 32GB
- High-speed USB 2.0 (backwards compatible with all USB 1.1 ports)
- Static and dynamic wear-leveling
- Error Correction: Up to 15bit BCH ECC per 528 Bytes
- SLC modules available in Commercial or Industrial Temperature
- MLC modules available in Commercial Temperature

**Supported Operating Systems**

Embedded USB flash operates as a disk drive via an internal USB header connector. It is compatible with the following operating systems:

Windows Vista / XP / 2000

Linux

**Options**

- Several USB connector options with 0.100" and 2mm pitch in various profiles.
- Factory configuration as Local or Removable disk drive.

# Table of Contents

## 1.0 General Specification

- 1.1 Recommended Temperature Conditions
- 1.2 Power Consumption
- 1.3 Performance
- 1.4 Dimensions
- 1.5 Ordering Information

## 2.0 USB Interface

- 2.1 USB Pin Header Description

## 3.0 Electrical Characteristics

- 3.1 Absolute Maximum Ratings
- 3.2 DC Characteristics

# Table of Figures and Tables

## Figures

- Fig 1 - Dimensions (std. profile)
- Fig 2 - Dimensions (low profile)
- Fig 3 - USB Pin Header

## Tables

- Table 1 - Power Consumption
- Table 2 - Dimensions (std. profile)
- Table 3 - Dimension (low profile)
- Table 4 - Part Numbers
- Table 5 - Connector Options
- Table 6 - Signal/Pin Assignment
- Table 7 - Absolute Maximum Ratings
- Table 8 - DC Characteristics

## 1.0 General Specifications

### 1.1 Recommended Temperature Conditions

<u>Parameter</u>	<u>Min.</u>	<u>Max</u>
Storage Temperature	-50°C	100°C
MLC Commercial Operating Temperature	0°C	70°C
SLC Commercial Operating Temperature	0°C	70°C
SLC Industrial Operating Temperature	-40°C	85°C

### 1.2 Power Consumption (typical)

Table 1 – Power Consumption

<b>Item</b>	<b>Power Consumption (mA)</b>		
	<b>1 Flash Chip</b>	<b>2 Flash Chips</b>	<b>4 Flash Chips</b>
<b>Normal</b>	50.6	53.6	54.3
<b>Suspend</b>	0.07	0.08	0.08
<b>Read</b>	94.0	82.4	123.8
<b>Write</b>	118.5	119.8	135.6

### 1.3 Performance

<u>Parameter</u>	<u>Value</u>
“High Speed” Transfer Rate	up to 480 Mbits/sec for USB 2.0
“Full Speed” Transfer Rate	up to 12 Mbits/sec for USB 1.1

### 1.4 Dimensions

Table 2 – Dimensions Standard Connector

Height	10.35mm (7.4mm connector, 0.062"PCB)
Width	26.6mm
Length	36.9mm
Maximum unit weight	5g

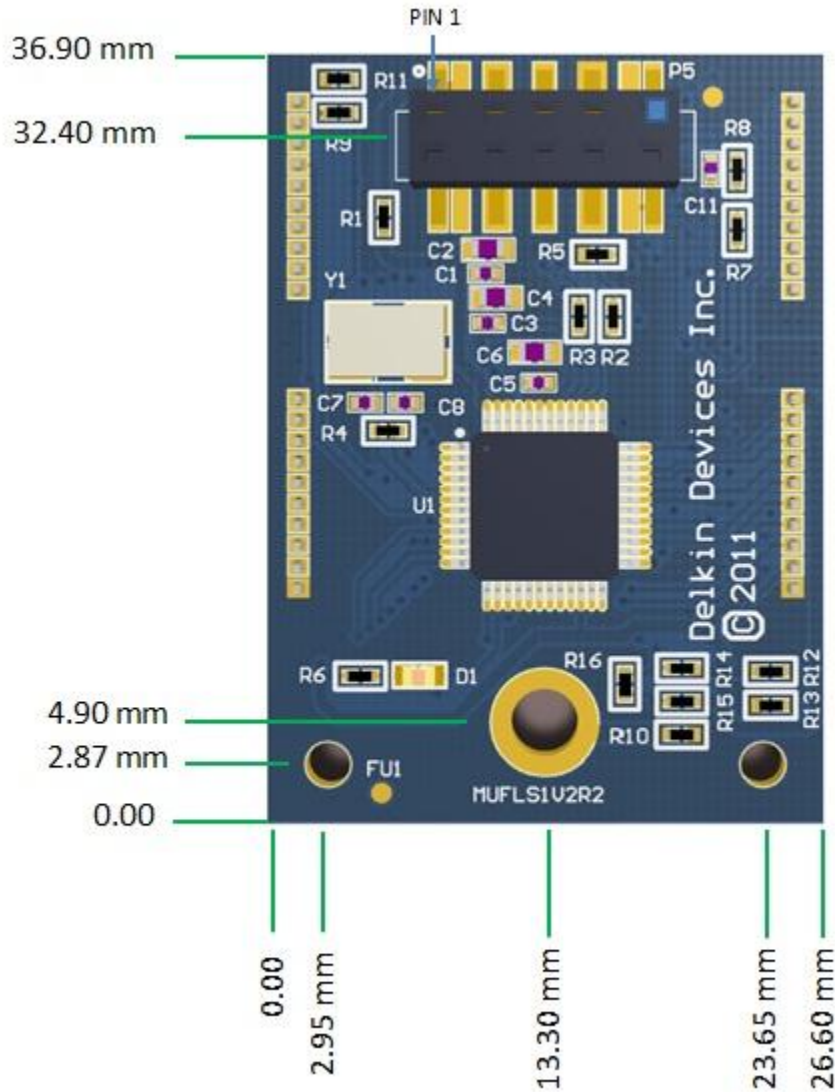

Fig 1 – Dimensions Standard Connector (0.100" pitch conn.)

Table 3 – Dimensions low profile

Height	6.51mm (3.68mm connector, 0.062"PCB)
Width	26.6mm
Length	36.9mm
Maximum unit weight	5g

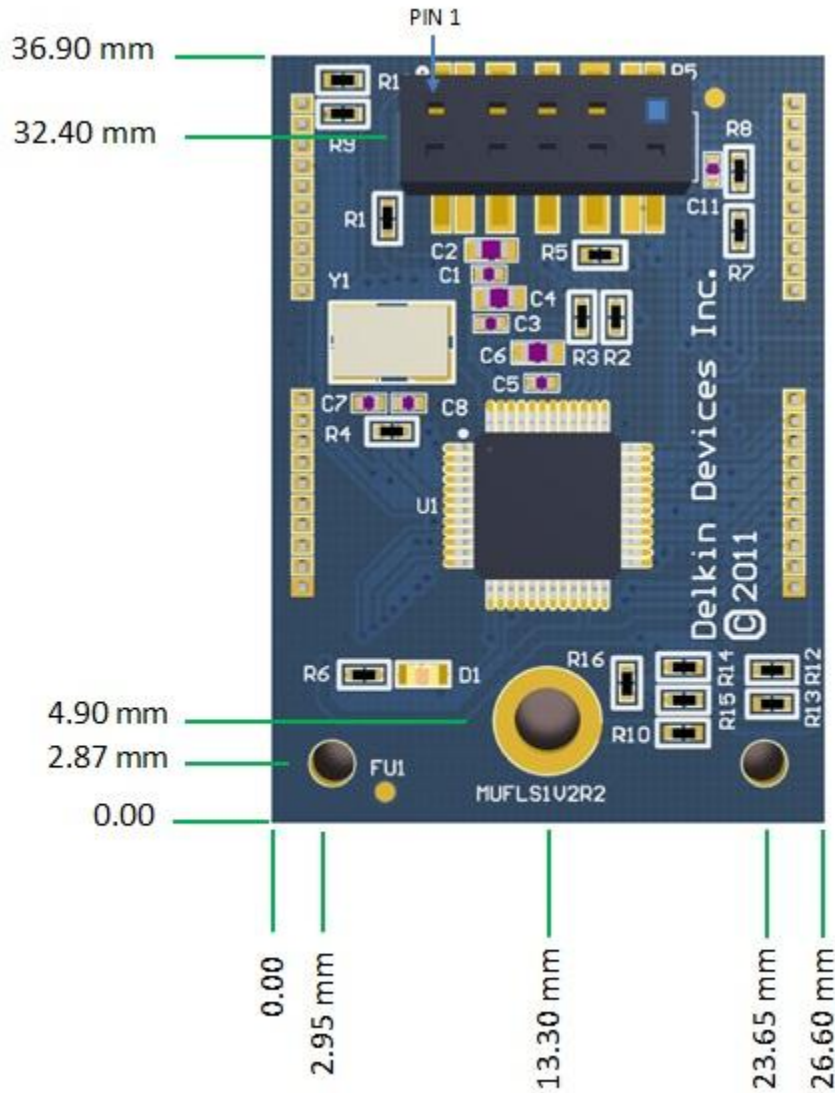

Fig 2 – Dimensions Low Profile (0.100" pitch conn.)

1.5 Ordering Information

The most common ordering configurations are given below:

Table 4 – Part Numbers

Capacity	Product Grade	Delkin Part Number(s)
4GB	MLC Commercial (0 to +70C)	MU04NFESW-xx000-D
8GB	MLC Commercial (0 to +70C)	MU08LCDSW-xx000-D
16GB	MLC Commercial (0 to +70C)	MU16LBZSW-xx000-D
32GB	MLC Commercial (0 to +70C)	MU32LBZSW-xx000-D
128MB	SLC Commercial (0 to +70C)	MV12SBFSW-xx000-D
256MB	SLC Commercial (0 to +70C)	MV25SBFSW-xx000-D MV25SBBSW-xx000-D
512MB	SLC Commercial (0 to +70C)	MV51SAWSW-xx000-D
1GB	SLC Commercial (0 to +70C)	MV0GSARSW-xx000-D
2GB	SLC Commercial (0 to +70C)	MV02SALSW-xx000-D MV02TFHSW-xx000-D
4GB	SLC Commercial (0 to +70C)	MV04SALSW-xx000-D MV04TFNSW-xx000-D
8GB	SLC Commercial (0 to +70C)	MV08TFPSW-xx000-D
16GB	SLC Commercial (0 to +70C)	MV16MGFSW-xx000-D MH16TFPSW-xx000-D
128MB	SLC Industrial (-40 to +85C)	MY12SBGSY-xx000-D
256MB	SLC Industrial (-40 to +85C)	MY25SBGSY-xx000-D
512MB	SLC Industrial (-40 to +85C)	MY51SAXSY-xx000-D
1GB	SLC Industrial (-40 to +85C)	MY0GSASSY-xx000-D MY0GSAXSY-xx000-D
2GB	SLC Industrial (-40 to +85C)	MY02SAMSU-xx000-D MY02TFHSY-xx000-D
4GB	SLC Industrial (-40 to +85C)	MY04SAMSU-xx000-D MY04TFNSY-xx000-D
8GB	SLC Industrial (-40 to +85C)	MY08TFPSY-xx000-D
16GB	SLC Industrial (-40 to +85C)	MY16MGFSY-xx000-D MJ16TFPSY-xx000-D

xx= connector designation (see table on next page for options)

1.6 Connector Options



Table 5 – Connector Options

Code	Pitch	Height	Orientation	Fixed / Removable	Connector Part #
RA	0.100"	10.35mm	Right Angle	Removable	Sullins NPPC052KFMS-RC
R1	0.100"	6.51mm	Right Angle	Removable	Samtec HLE-105-02-G-DV
R2	2mm	7.55mm	Right Angle	Removable	Samtec MMS-105-02-L-DV
R3	2mm	5.11mm	Right Angle	Removable	Samtec CLT-105-02-G-D
R4	0.100"	6.51mm	Right Angle	Fixed Disk	Samtec HLE-105-02-G-DV
R5	2mm	7.55mm	Right Angle	Fixed Disk	Samtec MMS-105-02-L-DV
R6	2mm	5.11mm	Right Angle	Fixed Disk	Samtec CLT-105-02-G-D
R7	0.100"	10.35mm	Right Angle	Fixed Disk	Sullins NPPC052KFMS-RC
R8	0.100"	10.35mm	Right Angle	Removable No keying plug at Pin 9	Sullins NPPC052KFMS-RC
ST	2mm	7.04mm	Straight	Removable	Samtec MMS-105-02-L-DH
SF	2mm	7.04mm	Straight	Fixed Disk	Samtec MMS-105-02-L-DH

Note: Tolerance for the height is +/- .25mm

## 2.0 USB Interface

### 2.1 USB Pin Header Description

Table 6 – Signal/Pin Assignment

Pin No.	Pin Type	Description
1	VCC	5.0V USB Bus Power Input.
2	NC	Not Connected
3	DM	USB 2.0 data in negative pin terminal.
4	NC	Not Connected
5	DP	USB 2.0 data in positive pin terminal.
6	NC	Not Connected
7	GND	0V regulator ground reference input.
8	NC	Not Connected
9	NC	Not Connected
10	SHD	Ground Shield (Option External LED)

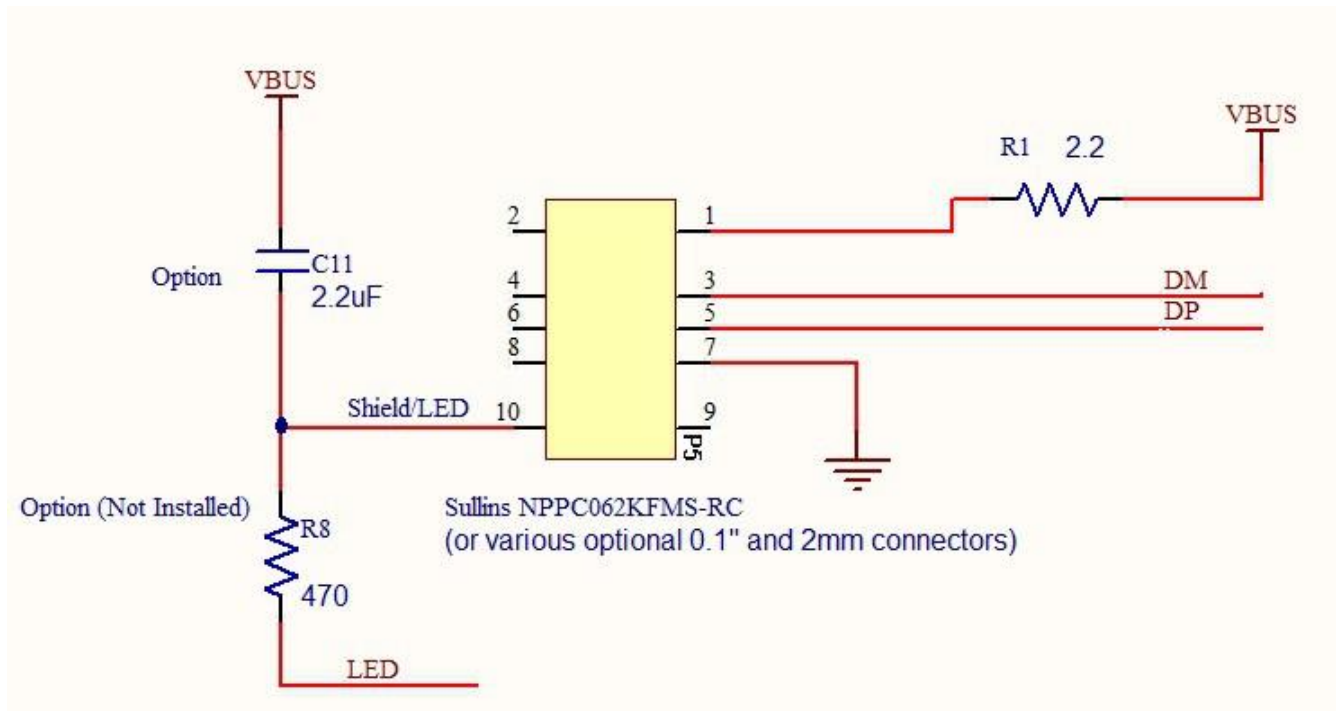

Fig 3 – USB Pin Header

### 3.0 Electrical Characteristics

#### 3.1 Absolute Maximum Ratings

Stresses in excess of the absolute maximum ratings can cause permanent damage to the device. These are absolute stress ratings only. Functional operation of the device is not implied at these or any other conditions in excess of those given in the operations sections of this data sheet. Exposure to absolute maximum ratings for extended periods can adversely affect device reliability.

Table 7 – Absolute Maximum Ratings

Parameter	Symbol	Min	Max	Unit
DC Power Supply	VDD - VSS	-0.3	+5.5	V
Input Voltage	VIN	VSS-0.3	VDD+0.3	V

Parameter	Symbol	Min	Typ	Max	Unit
VDD Voltage	VDD	4.5	5.0	5.5	V

#### 3.2 DC Characteristics

Table 8 – DC characteristics of 3.3V I/O Cells

Parameter	Symbol	Conditions	Min	Typ	Max	Unit
Core Power Supply	VCKK	Core Area	1.62	1.8	1.98	V
Power Supply	VCC3IO	3.3V I/O	3.0	3.3	3.6	V
Junction Temperature	Temp		0	25	115	°C
Switching threshold	Vt	LVTTL		1.5		V
Schmitt Trigger Negative Going threshold voltage	Vt-	LVTTL	0.8	1.1		V
Schmitt Trigger Positive Going threshold voltage	Vt+			1.6	2.0	V
Output Low voltage	Vol	[Iol] = 2 ~ 16mA			0.4	V
Output High voltage	Voh	[Ioh] = 2 ~ 16mA	2.4			V
Input Pull-Up Resistance	Rpu	PU=high, PD=low	40	75	190	KΩ
Input Pull-Down Resistance	Rpd	PU=high, PD=low	40	75	190	KΩ
Input Leakage Current	Iin	Vin = VCC3I or 0			1	μA
Tri-state Output Leakage Current	Ioz		-10	±1	10	μA