

# DELKIN DEVICES®

## High Performance SLC Industrial CompactFlash

### Engineering Specification

Document Number L5006

Revision: 1.4



No part of this document may be reproduced, copied, recorded, stored in a retrieval system, or transmitted in any form without the written permission of Delkin Devices. This document is for informational use only and is subject to change without prior notice. Delkin Devices assumes no responsibility for any errors that may appear in this document.

# Table of Contents

1.0	Product Overview.....	6
1.1	Part Numbers.....	8
1.2	Mechanical Specifications .....	9
1.3	Dimensions .....	9
2.0	Product Specifications .....	10
2.1	System Performance .....	10
2.2	Reliability .....	10
2.3	Environmental Specifications .....	10
2.4	CHS Parameters.....	10
3.0	CF Card Interface .....	12
3.1	Card Pin Assignment.....	12
3.2	Card Pin Explanation .....	13
4.0	Electrical Interface .....	20
4.1	Absolute Maximum Conditions .....	20
4.2	Input Power.....	20
4.3	Input Leakage Current .....	20
4.4	Input Characteristics .....	21
4.5	Output Drive Type.....	21
4.6	Output Drive Characteristics.....	21
4.7	Interface/Bus Timing.....	21
4.8	Attribute Memory Read Timing.....	22
4.9	Configuration Register (Attribute Memory) Write Timing.....	23
4.10	Common Memory Read Timing.....	24
4.11	Common Memory Write Timing.....	24
4.12	I/O Input (Read) Timing .....	25
4.13	I/O Input (Write) Timing .....	26
4.14	True IDE PIO Mode Read/Write Timing .....	27
4.15	True IDE Multiword DMA Mode Read/Write Timing.....	29
5.0	Card Configuration.....	32
5.1	Delkin Card Configuration .....	32
5.2	Attribute Memory Function .....	34
5.3	Configuration Option Register (Address 200H in Attribute Memory) .....	35
5.4	Card Configuration and Status Register (Address 200H in Attribute Memory) .....	36
5.5	Pin Replacement Register (Address 200H in Attribute Memory) .....	37
5.6	Socket and Copy Register (Address 200H in Attribute Memory) .....	38
6.0	Transfer Functions .....	39
6.1	Input/Output.....	39
6.2	Common Memory .....	40
6.3	True IDE Mode I/O.....	40

7.0	Software Interface.....	42
7.1	CF-ATA Drive Register Set Definition and Protocol.....	42
7.2	I/O Primary and Secondary Address Configurations.....	42
7.3	Contiguous I/O Mapped Addressing.....	43
7.4	Memory Mapped Addressing.....	45
7.5	True IDE Mode Addressing.....	46
7.6	CF-ATA Registers.....	47
7.6.1	Data Register (Address – 1F0H[170H]; Offset 0,8,9).....	47
7.6.2	Error Register (Address – 1F1H [171H]; Offset 1, 0DH Read Only).....	49
7.6.3	Feature Register (Address – 1F1H[171H]; Offset 1, 0DH Write Only).....	49
7.6.4	Sector Number (LBA 7-0) Register (Address – 1F3H[173H]; Offset 3).....	49
7.6.5	Cylinder Low (LBA 15-8) Register (Address – 1F4H[174H]; Offset 4).....	49
7.6.6	Cylinder High (LBA 23-16) Register (Address – 1F5H[175H]; Offset 5).....	49
7.6.7	Drive/Head (LBA 27-24) Register (Address 1F6H[176H]; Offset 6).....	50
7.6.8	Drive/Head (LBA 27-24) Register (Address 1F6H[176H]; Offset 6).....	50
7.6.9	Status & Alternate Status Registers (Address 1F7H[177H]&3F6H[376H]; Offsets 7 & E).....	51
7.6.10	Device Control Register (Address – 3F6H[376H]; Offset E).....	52
7.6.11	Card (Drive) Address Register (Address – 3F7H[377H]; Offset F).....	52
7.7	CF-ATA Command Description.....	53
7.7.1	CF-ATA Command set.....	54
7.7.2	Check Power Mode – 98H or E5H.....	56
7.7.3	Execute Drive Diagnostics – 90H.....	57
7.7.4	Erase Sector(s) – C0H.....	58
7.7.5	Flush Cache – E7h.....	58
7.7.6	Format Track – 50H.....	59
7.7.7	Identify Drive - ECH.....	59
7.7.7.1	General Configuration.....	61
7.7.7.2	Default Number of Cylinders.....	61
7.7.7.3	Default Number of Heads.....	61
7.7.7.4	Default Number of Sectors per Track.....	61
7.7.7.5	Number of Sectors per Card.....	61
7.7.7.6	Serial Number.....	61
7.7.7.7	ECC Count.....	62
7.7.7.8	Firmware Revision.....	62
7.7.7.9	Model Number.....	62
7.7.7.10	Read/Write Multiple Sector Count.....	62
7.7.7.11	Capabilities.....	62
7.7.7.12	PIO Data transfer Cycle Timing Mode.....	62
7.7.7.13	Translation Parameters Valid.....	62
7.7.7.14	Current Number of Cylinders, Heads, Sectors/Track.....	62
7.7.7.15	Current Capacity.....	62
7.7.7.16	Multiple Sector Setting.....	63

7.7.7.17	Total Sectors Addressable in LBA Mode .....	63
7.7.7.18	Multiword DMA transfer .....	63
7.7.7.19	Advanced PIO transfer modes supported .....	63
7.7.7.20	Minimum Multiword DMA transfer cycle time .....	63
7.7.7.21	Recommended Multiword DMA transfer cycle time.....	64
7.7.7.22	Minimum PIO transfer cycle time without flow control .....	64
7.7.7.23	Minimum PIO transfer cycle time with IORDY .....	64
7.7.7.24	Security Status.....	65
7.7.8	Idle – 97H or E3H .....	66
7.7.9	Idle Immediate – 95H or E1H .....	66
7.7.10	Initialize Drive Parameters – 91H .....	67
7.7.11	Key Management Structure Read – B9h (Feature: 0-127).....	67
7.7.12	Key Management Read Keying Material - B9h (Feature: 80) .....	68
7.7.13	Key Management Change Key Management Value – B9h (Feature: 81).....	69
7.7.14	NOP - 00h.....	69
7.7.15	Read Buffer – E4H.....	70
7.7.16	Read DMA – C8h.....	70
7.7.17	Read Long Sector - 22h or 23h .....	71
7.7.18	Read Multiple – C4H.....	72
7.7.19	Read Sector(s) – 20H or 21H .....	73
7.7.20	Read Verify Sector(s) – 40H or 41H.....	74
7.7.21	Recalibrate – 1XH.....	74
7.7.22	Request Sense – 03H.....	75
7.7.23	Security Disable Password - F6h .....	76
7.7.24	Security Erase Prepare - F3h .....	77
7.7.25	Security Erase Unit - F4h.....	78
7.7.26	Security Freeze Lock - F5h.....	78
7.7.27	Security Set Password - F1h .....	79
7.7.28	Security Unlock - F2h .....	79
7.7.29	Seek – 7XH.....	80
7.7.30	Set Feature – EFH.....	81
7.7.31	Set Multiple Mode – C6H.....	82
7.7.32	Set Sleep Mode – 99H or E6H .....	83
7.7.33	Standby – 96H or E2H.....	84
7.7.34	Standby – 94H or E0H.....	84
7.7.35	Translate Sector – 87H.....	85
7.7.36	Wear Level – F5H.....	86
7.7.37	Write Buffer – E8H.....	86
7.7.38	Write DMA – CAh .....	87
7.7.39	Write Long Sector – 32H or 33H .....	88
7.7.40	Write Multiple Command – C5H .....	88
7.7.41	Write Multiple without Erase – CDH .....	90
7.7.42	Write Sector(s) – 30H or 31H .....	90
7.7.43	Write Sector(s) without Erase – 38H .....	91

7.7.44	Write Verify – 3CH .....	92
7.8	Error Posting .....	92
8.0	Comparing CF-ATA to PC Card-ATA and True IDE .....	95
8.1	Electrical Differences .....	95
8.1.1	TTL Compatibility .....	95
8.1.2	Pull Up Resistor Input Leakage Current .....	95
8.2	Functional Differences .....	95
8.2.1	Additional Set Features Codes in CF-ATA .....	95
8.2.2	Additional Commands in CF-ATA .....	95
8.2.3	Idle Timer .....	96
8.2.4	Recovery from Sleep Mode .....	96

## Table of Figures

Figure 1.	CF Card Dimensions .....	9
Figure 2.	Attribute Memory Read Timing Diagram .....	22
Figure 3.	Configuration Register (Attribute Memory) Write Timing Diagram .....	23
Figure 4.	Common Memory Read Timing Diagram .....	24
Figure 5.	Common Memory Write Timing Diagram .....	25
Figure 6.	I/O read Timing Diagram .....	26
Figure 7.	I/O Write Timing Diagram .....	27
Figure 8.	True IDE PIO Mode Read/Write Timing Diagram .....	29
Figure 9.	True IDE Multiword DMA Mode Read/Write Timing Diagram .....	31

# 1.0 Product Overview

Delkin's *High Performance Industrial Temperature CompactFlash* memory cards feature significant performance upgrades for industrial applications. These cards have superior features such as:

- Global Wear Leveling
- ECC error correction 15 bit / 512 Byte
- Up to 95 MB/sec sustained write speed\*
- Industrial temperature (-40 to 85 °C) operating range
- Compliant with CompactFlash Specification Rev. 4.1, Type 1, and ATA/ATAPI-7
- Operating modes – Memory, PCMCIA I/O, True IDE (PIO6 & DMA4) IDE UDMA6, PCMCIA UDMA6
- Compliant with European Union Directive 2002/95/EC (RoHS)
- Shock: 40g's at 11ms, MIL-STD-810, Method 516.6
- Vibration: 15Hz to 2,000Hz, MIL-STD-810, Method 514.5
- Humidity: 95% R-H, MIL-STD-810, Method 507.4
- Altitude: 80,000 feet
- Capacities supported: 4GB, 8GB, 16GB, 32 GB & 64 GB (Other capacities available upon request.)
- NAND Single Level Cell flash (SLC)
- Supports 3.3-Volt and 5-Volt operation
- Fixed Drive available
- Solid State – no moving parts
- Ultrasonic welded case – No press fit components
- Available upon request – Custom CIS, mechanical features, labels and packaging
- All capacity configurations are available with Delkin's Tekta™ infusion process proprietary conformal coating

\*Dependent on host configuration and testing equipment.

The High Performance SLC Industrial CompactFlash cards are manufactured in the USA at our own facilities in Poway, California. The cards are supported by Delkin's locked-down Bill of Materials that ensures consistent product performance and future compatibility. Delkin's Industrial line of CompactFlash is the perfect solution for enterprises demanding specific higher qualitative and performance functions in a widely accepted, time-tested form factor.

**Applications:**

- Industrial Computers
- Embedded Systems
- Data Acquisition
- Automotive
- Flight Systems
- Manufacturing
- Military
- Telecommunications
- Agriculture
- Gaming

**Tekta™ Infusion Conformal Coating**

Tekta infusion, Delkin's proprietary conformal coating, defends data integrity in harsh environments. Tekta is a low-viscosity silicon elastomer that thoroughly covers exposed board and component surfaces with a protective coating. Tekta shields memory electronics from moisture and contamination, preventing metal corrosion and insulating conductors against electrical leakage. Tekta also ruggedizes devices against the vibration, shock, and thermal stress of severe-service applications. The Tekta coating is available as an option for Delkin industrial flash memory products in many form factors, including solid state drives, CompactFlash, Secure Digital, removable and embedded USB, PCMCIA, and mSATA.

## 1.1 Part Numbers

Delkin Devices High Performance SLC Industrial CompactFlash cards are available in the following Configurations:

Capacity	Configuration	Part Number
4 GB	Fixed Drive, DMA ON	CE04TFHVA-FD000-D
	Fixed Drive, DMA OFF	CE04TFHVA-F1000-D
	Removable, DMA ON	CE04TFHVA-XX000-D
	Removable DMA, OFF	CE04TFHVA-X1000-D
8 GB	Fixed Drive, DMA ON	CE08TFNVA-FD000-D
	Fixed Drive, DMA OFF	CE08TFNVA-F1000-D
	Removable, DMA ON	CE08TFNVA-XX000-D
	Removable DMA, OFF	CE08TFNVA-X1000-D
16 GB	Fixed Drive, DMA ON	CE16TFPVA-FD000-D
	Fixed Drive, DMA OFF	CE16TFPVA-F1000-D
	Removable, DMA ON	CE16TFPVA-XX000-D
	Removable DMA, OFF	CE16TFPVA-X1000-D
32 GB	Fixed Drive, DMA ON	CE32MGGVA-FD000-D
	Fixed Drive, DMA OFF	CE32MGGVA-F1000-D
	Removable, DMA ON	CE32MGGVA-XX000-D
	Removable DMA, OFF	CE32MGGVA-X1000-D
64 GB	Fixed Drive, DMA ON	CE64MGMVA-FD000-D
	Fixed Drive, DMA OFF	CE64MGMVA-F1000-D
	Removable, DMA ON	CE64MGMVA-XX000-D
	Removable DMA, OFF	CE64MGMVA-X1000-D
<b>Notes:</b>		
<ul style="list-style-type: none"> <li>To add Tekta™ Infusion Conformal Coating, change the 000 in the part number to 050.</li> </ul>		

The CompactFlash cards are manufactured at our facilities in Poway, California USA. Many custom configurations are available including custom CIS, mechanical features, labels and packaging.

## 1.2 Mechanical Specifications

Delkin Devices High Performance SLC Industrial cards are Type I CompactFlash cards.

## 1.3 Dimensions

Length:	36.4 ± 0.15 mm (1.433 ± .006 in.)
Width:	42.80 ± 0.10 mm (1.685 ± .004 in.)
Thickness Including Label Area:	3.3 mm ± 0.10 mm (.130 ± .004 in.)
Weight:	12.0 g typical

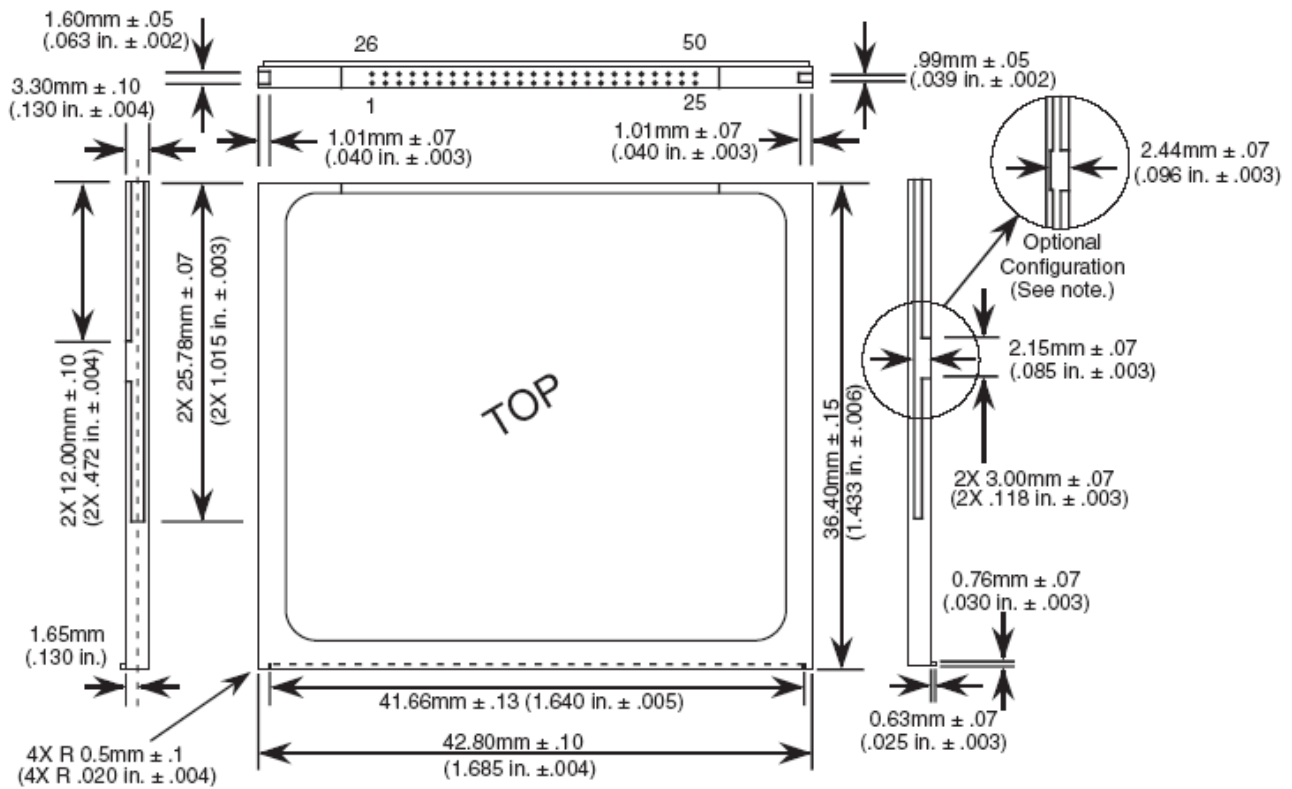

Note: The optional notched configuration was shown in the CF Specification Rev. 1.0. In specification Rev. 1.2, the notch was removed for ease of tooling. This optional configuration can be used but it is not recommended.

Figure 1. CF Card Dimensions

## 2.0 Product Specifications

### 2.1 System Performance

Parameter	Value
Data Transfer Rate	Up to 105 MB/s
Sustained Read	Up to 105 MB/s
Sustained Write	Up to 95 MB/s

**Note:** All values dependent on configuration and testing environment.

### 2.2 Reliability

Parameter	Value
Cycle Endurance**	2,000,000 cycles min.
MTBF***	>2,000,000 hours
Data Retention	10 Years
Connector Durability	10,000 insertion cycles

\*\* Reference Delkin Reliability *Test Report for Compact Flash, Secure Digital, USB and Embedded USB Drives* (Document Number L5002).

\*\*\* Dependent on configuration and testing environment

### 2.3 Environmental Specifications

Features	Operating
Storage Temperature	-50 ~ 100°C
Industrial Operating Temperature	-40 ~ 85°C
Humidity	5% – 95% RH, non-condensing
Vibration	15Hz to 2000Hz (MIL-STD-810, Method 514.5)
Shock	40g's at 11ms
Altitude	80,000 feet max.

### 2.4 CHS Parameters

Capacity	Cylinders	Heads	Sectors/Track
4GB	7964	16	63
8GB	15538	16	63
16GB	16383	15	63
32GB	16383	15	63

64GB	16383	15	63
------	-------	----	----

## 3.0 CF Card Interface

### 3.1 Card Pin Assignment

Pin No.	Memory card mode		I/O card mode		True IDE mode	
	Signal Name	I/O	Signal Name	I/O	Signal Name	I/O
1	GND	—	GND	—	GND	—
2	D3	I/O	D3	I/O	D3	I/O
3	D4	I/O	D4	I/O	D4	I/O
4	D5	I/O	D5	I/O	D5	I/O
5	D6	I/O	D6	I/O	D6	I/O
6	D7	I/O	D7	I/O	D7	I/O
7	-CE1	I	-CE1	I	-CS0	I
8	A10	I	A10	I	A10	I
9	-OE	I	-OE	I	-ATASEL	I
10	A9	I	A9	I	A9	I
11	A8	I	A8	I	A8	I
12	A7	I	A7	I	A7	I
13	Vcc	—	Vcc	—	Vcc	—
14	A6	I	A6	I	A6	I
15	A5	I	A5	I	A5	I
16	A4	I	A4	I	A4	I
17	A3	I	A3	I	A3	I
18	A2	I	A2	I	A2	I
19	A1	I	A1	I	A1	I
20	A0	I	A0	I	A0	I
21	D0	I/O	D0	I/O	D0	I/O
22	D1	I/O	D1	I/O	D1	I/O
23	D2	I/O	D2	I/O	D2	I/O
24	WP	O	-IOIS16	O	-IOCS16	O
25	-CD2	O	-CD2	O	-CD2	O
26	-CD1	O	-CD1	O	-CD1	O
27	D11	I/O	D11	I/O	D11	I/O

Pin No.	Memory card mode		I/O card mode		True IDE mode	
	Signal Name	I/O	Signal Name	I/O	Signal Name	I/O
28	D12	I/O	D12	I/O	D12	I/O
29	D13	I/O	D13	I/O	D13	I/O
30	D14	I/O	D14	I/O	D14	I/O
31	D15	I/O	D15	I/O	D15	I/O
32	-CE2	I	-CE2	I	-CS1	I
33	-VS1	O	-VS1	O	-VS1	O
34	-IORD	I	-IORD	I	-IORD	I
35	-IOWR	I	-IOWR	I	-IOWR	I
36	-WE	I	-WE	I	-WE	I
37	RDY/-BSY	O	-IREQ	O	INTRQ	O
38	Vcc	—	Vcc	—	Vcc	—
39	-CSEL	I	-CSEL	I	-CSEL	I
40	-VS2	O	-VS2	O	-VS2	O
41	RESET	I	RESET	I	-RESET	I
42	-WAIT	O	-WAIT	O	IORDY	O
43	-INPACK	O	-INPACK	O	DMARQ	O
44	-REG	I	-REG	I	-DMACK	I
45	BVD2	I/O	-SPKR	I/O	-DASP	I/O
46	BVD1	I/O	-STSCHG	I/O	-PDIAG	I/O
47	D8	I/O	D8	I/O	D8	I/O
48	D9	I/O	D9	I/O	D9	I/O
49	D10	I/O	D10	I/O	D10	I/O
50	GND	—	GND	—	GND	—

## 3.2 Card Pin Explanation

Signal Name	Direction	Pin Number	Description
A10 to A0 (PC Card Memory mode)	I	8, 10, 11, 12, 14, 15, 16, 17, 18,	Address bus is A10 to A0. A10 is MSB and A0 is LSB.

Signal Name	Direction	Pin Number	Description
A10 to A0 (PC Card Memory mode)		19, 20	
A2 to A0 (True IDE mode)		18, 19, 20	Address bus is A10 to A0. Only A2 to A0 are used, A10 to A3 should be grounded by the host.
BVD1 (PC Card Memory mode)			BVD1 outputs the battery voltage status in the card. This output line is constantly driven to a high state since a battery is not required for this product.
-STSCHG (PC Card I/O mode)	I/O	46	-STSCHG is used for changing the status of Configuration and status register in attribute area.
-PDIAG (True IDE mode)			-PDIAG is the Pass Diagnostic signal in Master/Slave handshake protocol.
BVD2 (PC Card Memory mode)			BVD2 outputs the battery voltage status in the card. This output line is constantly driven to a high state since a battery is not required for this product.
-SPKR (PC Card I/O mode)	I/O	45	-SPKR outputs speaker signals. This output line is constantly driven to a high state since this product does not support the audio function.
-DASP (True IDE mode)			-DASP is the Disk Active/Slave Present signal in the Master/Slave handshake protocol.
-CD1, -CD2 (PC Card Memory mode)			-CD1 and -CD2 are the card detection signals. -CD1 and -CD2 are connected to ground, so host can detect that the card is inserted or not.
-CD1, -CD2 (PC Card I/O mode)	O	26, 25	
-CD1, -CD2 (True IDE mode)			
-CE1, -CE2 PC Card Memory mode Card Enable	I	7, 32	-CE1 and -CE2 are low active card select signals. Byte/Word/Odd byte modes are defined by combination Card Enable of -CE1,

Signal Name	Direction	Pin Number	Description
-CE1, -CE2 (PC Card I/O mode) Card Enable			-CE2 and A0.
-CS0, -CS1 (True IDE mode) Card Enable			-CE2 is used for select the Alternate Status Register and the Device Control Register while -CE1 is the chip select for the other task file registers.
-CSEL (PC Card Memory mode)	I	39	This signal is not used.
-CSEL (PC Card I/O mode)			
-CSEL (True IDE mode)			This signal is used to configure this device as a Master or a Slave when configured in the True IDE mode. When this pin is grounded, this device is configured as a Master. When the pin is open, this device is configured as a Slave.
D15 to D0 (PC Card Memory mode)	I/O	31, 30, 29, 28, 27, 49, 48, 47, 6, 5, 4, 3, 2, 23, 22, 21	Data bus is D15 to D0. D0 is the LSB of the even byte of the word. D8 is the LSB of the odd byte of the word.
D15 to D0 (PC Card I/O mode)			
D15 to D0 (True IDE mode)			
GND (PC Card Memory mode)	—	1, 50	Ground
GND (PC Card I/O mode)			
GND (True IDE mode)			
-INPACK (PC Card Memory mode)	O	43	This signal is not used and should not be connected at the host.

Signal Name	Direction	Pin Number	Description
-INPACK (PC Card I/O mode) Input Acknowledge			This signal is asserted low by this card when the card is selected and responding to an I/O read cycle at the address that is on the address bus during -CE and -IORD are low. This signal is used for the input data buffer control.
DMARQ (True IDE mode)			This signal is a DMA Request that is used for DMA data transfers between host and device.
-IORD (PC Card Memory mode)			This signal is not used.
-IORD (PC Card I/O mode)	I	34	-IORD is used for control of read data in I/O task file area. This card does not respond to -IORD until I/O card interface setting up.
-IORD (True IDE mode)			-IORD is used for control of read data in I/O task file area. This card does not respond to -IORD until True IDE interface setting up.
-IOWR (PC Card Memory mode)			This signal is not used.
-IOWR (PC Card I/O mode)	I	35	-IOWR is used for control of data write in I/O task file area. This card does not respond to -IOWR until I/O card interface setting up.
-IOWR (True IDE mode)			-IOWR is used for control of data write in I/O task file area. This card does not respond to -IOWR until True IDE interface setting up.
-OE (PC Card Memory mode)			-OE is used for the control of reading register's data in attribute area or task file area.
-OE (PC Card I/O mode)	I	9	-OE is used for the control of reading register's data in attribute area.
-ATASEL (True IDE mode)			To enable True IDE mode this input should be grounded by the host.

Signal Name	Direction	Pin Number	Description
RDY/-BSY (PC Card Memory mode)	O	37	The signal is RDY/-BSY pin. RDY/-BSY pin turns low level during the card internal initialization operation at Vcc applied or reset applied, so next access to the card should be after the signal turned high level.
-IREQ (PC Card I/O mode)			This signal is active low -IREQ pin. The signal of low level indicates that the card is requesting software service to host, and high level indicates that the card is not requesting.
INTRQ (True IDE mode)			This signal is the active high Interrupt Request to the host.
-REG (PC Card Memory mode)	I	44	-REG is used during memory cycles to distinguish between task file and attribute memory accesses. Attribute memory select High for task file, Low for attribute memory is accessed.
-REG (PC Card I/O mode)			-REG is constantly low when task file or attribute memory is accessed.
-DMACK (True IDE mode)			This is a DMA Acknowledge signal by the host in response to DMARQ to initiate DMA transfers.
RESET (PC Card Memory mode)	I	41	This signal is active high RESET pin. If this signal is asserted high, the card internal initialization begins to operate. During the card internal initialization RDY/-BSY is low. After the card internal initialization RDY/-BSY is high.
RESET (PC Card I/O mode)			This signal is active high RESET pin. If this signal is asserted high, the card internal initialization begins to operate. In this mode, RDY/-BSY signal cannot be used, so using Status Register the Ready/Busy status can be confirmed.

Signal Name	Direction	Pin Number	Description
-RESET (True IDE mode)			This signal is active low -RESET pin. If this signal is asserted low, all the registers in this card are reset. In this mode, RDY/-BSY signal cannot be used, so using status register the Ready/Busy status can be confirmed.
Vcc (PC Card Memory mode)	—	13, 38	+5 V, +3.3 V power.
Vcc (PC Card I/O mode)			
Vcc (True IDE mode)			
-VS1, -VS2 (PC Card Memory mode)	O	33, 40	These signals are intended to notify Vcc requirement to host. -VS1 is held grounded and -VS2 is non-connected in this card.
-VS1, -VS2 (PC Card I/O mode)			
-VS1, -VS2 (True IDE mode)			
-WAIT (PC Card Memory mode)	O	42	This signal is active low -WAIT pin. In this card this signal is constantly high level.
-WAIT (PC Card I/O mode)			
IORDY (True IDE mode)			
-WE (PC Card Memory mode)	I	36	-WE is used for the control of writing register's data in attribute memory area or task file area.
-WE (PC Card I/O mode)			-WE is used for the control of writing register's data in attribute memory area.
-WE (True IDE mode)			This input signal is not used and should be connected to Vcc by the host.

Signal Name	Direction	Pin Number	Description
WP (PC Card Memory mode)	O	24	WP is held low because this card does not have write-protect switch.
-IOIS16 (PC Card I/O mode)			-IOIS16 is asserted when task file registers are accessed in 16-bit mode.
-IOCS16 (True IDE mode)			This output signal is asserted low when this device is expecting a word data transfer cycle.

## 4.0 Electrical Interface

### 4.1 Absolute Maximum Conditions

Parameter	Symbol	Conditions
Input Power	Vcc	-0.3V min. to 6.5V Max
Voltage on any pin except Vcc with respect to GND	V	-0.5V min. to Vcc + 0.5V Max

### 4.2 Input Power

Voltage	Maximum Average RMS Active Current	Maximum Average RMS Sleep Current	Measurement Method
3.135-3.465V	75 mA	200 $\mu$ A	3.3V at 25°C <sup>1</sup>
4.5-5.5V	100 mA	300 $\mu$ A	5.0V at 25°C <sup>1</sup>

Current measurement is accomplished by connecting an amp meter (set to the 2 amp scale range) in series with the Vcc supply to the CompactFlash card. Current measurements are to be taken while looping on a data transfer command with a sector count of 128. Current consumption values for both Read and Write commands are not to exceed the Maximum Average RMS Current specified in this table.

CompactFlash products shall operate correctly in both voltage ranges as shown in the above. To comply with this specification, current requirements must not exceed the maximum limit.

### 4.3 Input Leakage Current

Type	Parameter	Symbol	Conditions	Min	Typ	Max	Units
IxZ	Input Leakage Current	IL	VHI = Vcc / VIL = GND	-1		1	$\mu$ A
IxU	Pull Up Resistor	RPU1	Vcc = 5.0V	50k		500k	Ohm
IxD	Pull Down Resistor	RPD1	Vcc = 5.0V	50k		500k	Ohm

## 4.4 Input Characteristics

Type	Parameter	Symbol	V <sub>CC</sub> = 3.3V		V <sub>CC</sub> = 5.0V		Units
			Min	Typ	Min	Typ	
1	Input Voltage CMOS	V <sub>Ih</sub> V <sub>Il</sub>	2.4	0.6	4.0	0.8	Volt s
2	Input Voltage CMOS	V <sub>Ih</sub> V <sub>Il</sub>	1.5	0.6	2.0	0.8	Volt s
3	Input Voltage CMOS Schmitt Trigger	V <sub>th</sub> V <sub>tl</sub>	1.8 1.0		2.8 2.0		Volt s

## 4.5 Output Drive Type

All outputs drive types are CMOS level.

## 4.6 Output Drive Characteristics

Type	Parameter	Symbol	Conditions	Min	Typ	Max	Units
O1	Output Voltage	V <sub>oh</sub> V <sub>ol</sub>	I <sub>oh</sub> = -4 mA I <sub>ol</sub> = 4 mA	V <sub>CC</sub> -0.8V		GND +0.4V	Volts
O2	Output Voltage	V <sub>oh</sub> V <sub>ol</sub>	I <sub>oh</sub> = -8 mA I <sub>ol</sub> = 8 mA	V <sub>CC</sub> -0.8V		GND +0.4V	Volts

## 4.7 Interface/Bus Timing

There are two types of bus cycles and timing sequences that occur in the PCMCIA type interface, a direct mapped I/O transfer and a memory access. The two timing sequences are explained in detail in the PCMCIA PC Card Standard. Delkin's CompactFlash Card conforms to the timing in that reference document.

### 4.8 Attribute Memory Read Timing

The Attribute Memory access time is defined as 300 ns.

Item	Symbol	IEEE Symbol	Min	Max	Units
Read Cycle Time	tc(R)	tAVAV	300		ns
Address Access Time	ta(A)	tAVQV		300	ns
Card Enable Access Time	ta(CE)	tELQV		300	ns
Output Enable Access Time	ta(OE)	tGLQV		150	ns
Output disable Time from CE	tdis(CE)	tEHQZ		100	ns
Output disable Time from OE	tdis(OE)	tGHQZ		100	ns
Address Setup Time	tsu(A)	tAVGL	30		ns
Output Enable Time from CE	ten(CE)	tELQNZ	5		ns
Output Enable Time from OE	ten(OE)	tGLQNZ	5		ns
Data Valid from Address Charge	tv(A)	tAXQX	0		ns

<sup>1</sup>All times are in nanoseconds. Dout signifies data provided by the CompactFlash card to the system. The -CE signal or both the -OE signal and the -WE must be de-asserted between consecutive cycle operations.

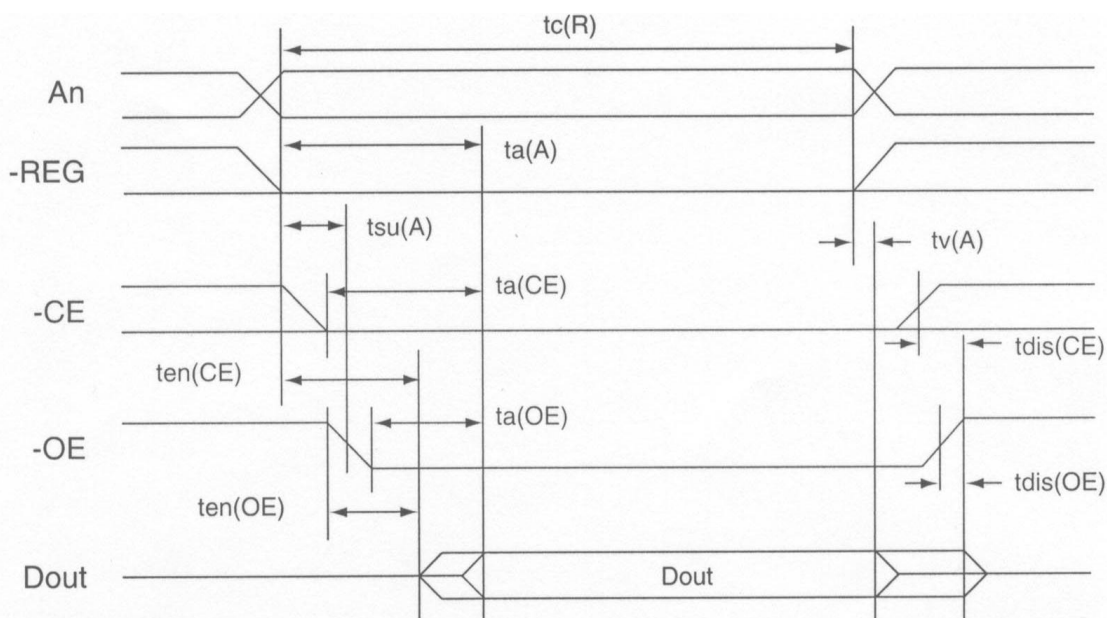

Figure 2. Attribute Memory Read Timing Diagram

### 4.9 Configuration Register (Attribute Memory) Write Timing

The Card Configuration write access time is defined as 250 ns.

Item	Symbol	IEEE Symbol	Min <sup>1</sup>	Max <sup>1</sup>	Units
Write Cycle Time	tc(W)	tAVAV	250		ns
Write Pulse Width	tw(WE)	tWLWH	150		ns
Address Setup Time	tsu(A)	tAVWL	30		ns
Write Recovery Time	Trec(WE)	tWMAX	30		ns
Data Setup Time for WE	tsu(D-WEH)	tDVWH	80		ns
Data Hold Time	th(D)	tWMDX	30		ns

<sup>1</sup>All times are in nanoseconds. DIN signifies data provided by the system to the CompactFlash card.

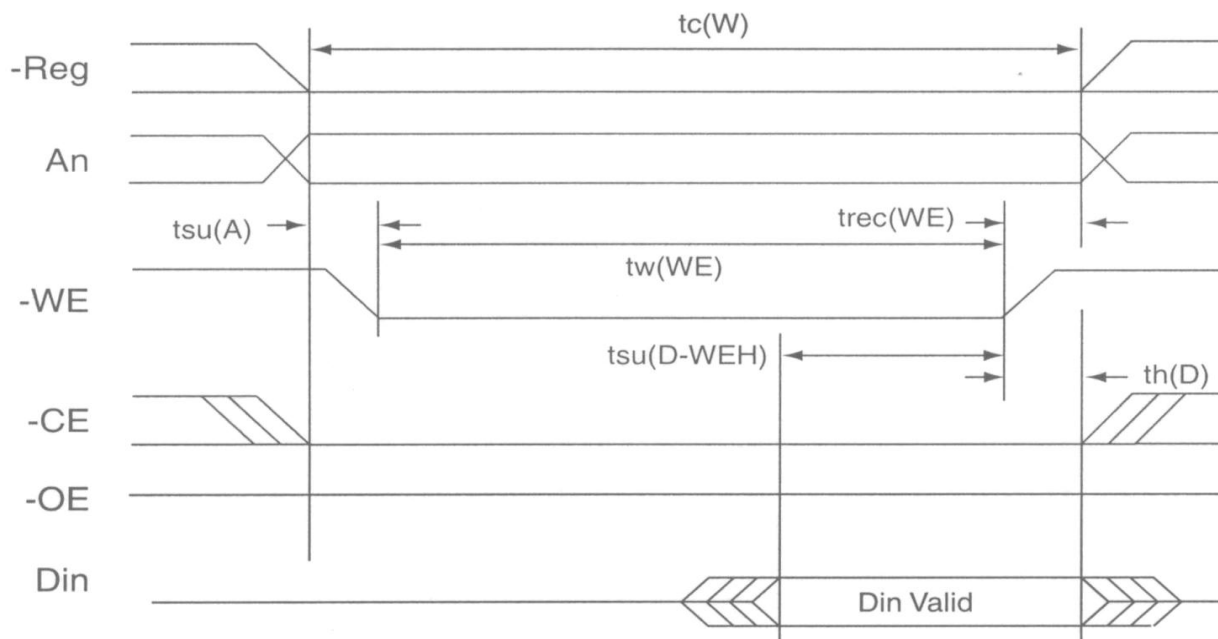

Figure 3. Configuration Register (Attribute Memory) Write Timing Diagram

### 4.10 Common Memory Read Timing

The Card Common Memory access time is defined as 250 ns.

Item	Symbol	IEEE Symbol	Min <sup>1</sup>	Max <sup>1</sup>
Output Enable Access Time	ta(OE)	tGLQV		125
Output Disable Time from OE	tdis(OE)	tGHQZ		100
Address Setup Time	Tsu(A)	tAVGL	30	
Address Hold Time	thA	tGHAX	20	
CE Setup before OE	Tsu(CE)	tELGL	5	
CE Hold following OE	th(CE)	tGHEH	20	

<sup>1</sup>All times are in nanoseconds.

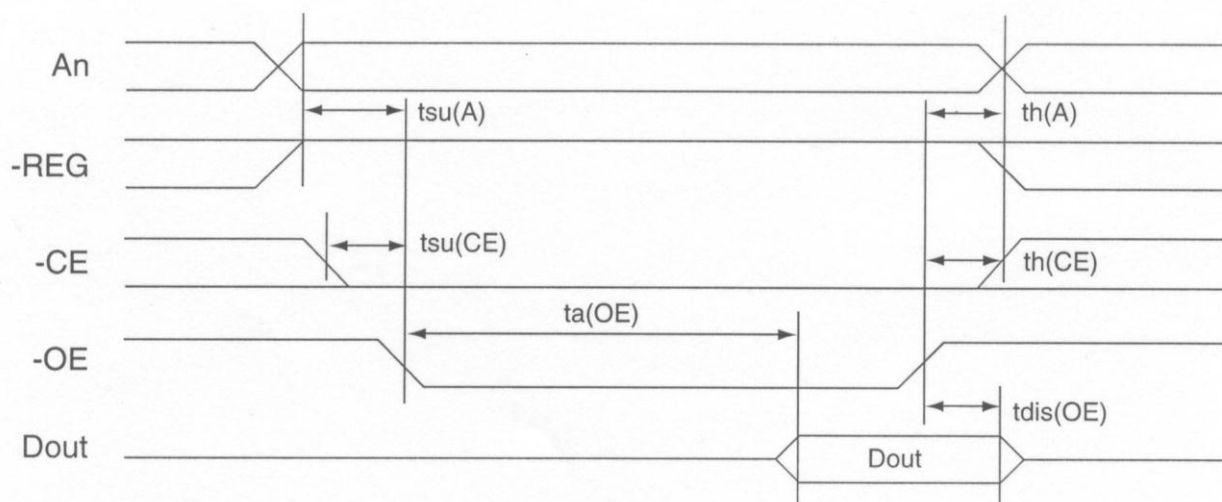

Figure 4. Common Memory Read Timing Diagram

### 4.11 Common Memory Write Timing

The Card Common Memory write access time is defined as 250 ns.

Item	Symbol	IEEE Symbol	Min <sup>1</sup> ns	Max <sup>1</sup> ns
Data Setup before WE	tsu(D-WEH)	tDVWH	80	
Data Hold following WE	th(D)	tWMDX	30	
WE Pulse Width	tw(WE)	tWLWH	150	

Item	Symbol	IEEE Symbol	Min <sup>1</sup> ns	Max <sup>1</sup> ns
Address Setup Time	tsu(A)	tAVWL	30	
CE Setup before WE	tsu(CE)	tELWL	5	
Write Recovery Time	trec(WE)	tWMAX	30	
Address Hold Time	th(A)	tGHAX	20	
CE Hold following WE	th(CE)	tGHEH	20	

<sup>1</sup>All times are in nanoseconds.

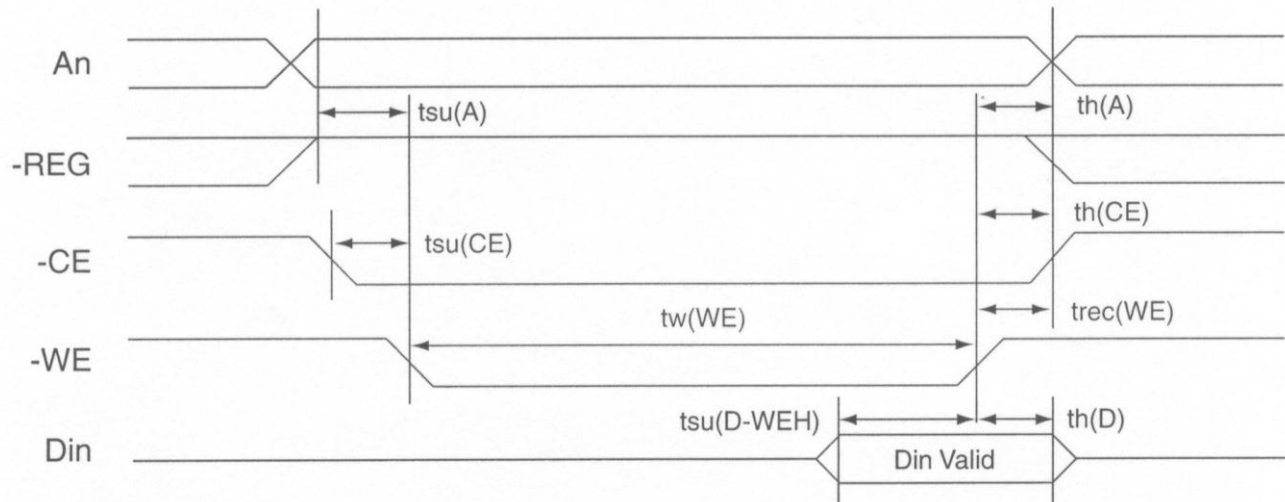

Figure 5. Common Memory Write Timing Diagram

### 4.12 I/O Input (Read) Timing

The Card I/O read access time is defined as 250 ns.

Item	Symbol	IEEE Symbol	Min <sup>1</sup>	Max <sup>1</sup>
Data Delay after IORD	td(IORD)	tIGLQV		100
Data Hold following IORD	th(IORD)	tIGHQX	0	
IORD Width Time	tw(IORD)	tIGLIGH	165	
Address Setup before IORD	tsuA(IORD)	tAVIGL	70	
Address Hold following IORD	thA(IORD)	tIGHAX	20	
CE Setup before IORD	tsuCE(IORD)	tELIGL	5	
CE Hold following IORD	thCE(IORD)	tIGHEH	20	
REG Setup before IORD	tsuREG(IORD)	tRGLIGL	5	
REG Hold following IORD	thREG(IORD)	tIGHRGH	0	

Item	Symbol	IEEE Symbol	Min <sup>1</sup>	Max <sup>1</sup>
INPACK Delay Falling from IORD	tdfINPACK(IORD)	tIGLIAL	0	45
INPACK Delay Rising from IORD	tdrINPACK(IORD)	tIGHIAH		45
IOIS16 Delay Falling from IORD	tdfIOIS16(ADR)	tAVISL		35
IOIS16 Delay Rising from IORD	tdrIOIS16(ADR)	tAVISH		35

<sup>1</sup>All times are in nanoseconds.

**Note:** The maximum load on –INPACK and IOIS16 is 1 LSTTL with 50pF total load.

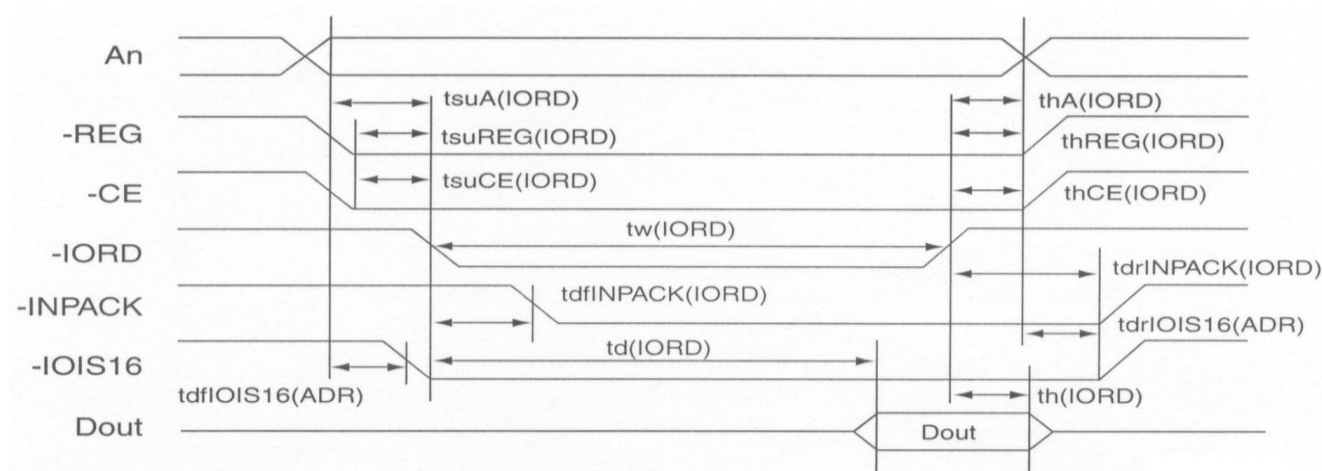

Figure 6. I/O read Timing Diagram

## 4.13 I/O Input (Write) Timing

The Card I/O Input write access time is defined as 250 ns.

Item	Symbol	IEEE Symbol	Min <sup>1</sup>	Max <sup>1</sup>
Data Setup before IOWR	tsu(IOWR)	tDVIWH	60	
Data Hold following IOWR	th(IOWR)	tIWHDX	30	
IOWR Width Time	tw(IOWR)	tIWLWH	165	
Address Setup before IOWR	tsuA(IOWR)	tAVIWL	70	
Address Hold following IOWR	thA(IOWR)	tIWHAX	20	
CE Setup before IOWR	tsuCE(IOWR)	tELIWL	5	
CE Hold following IOWR	thCE(IOWR)	tIWHEH	20	
REG Setup before IOWR	tsuREG(IOWR)	tRGLIWL	5	
REG Hold following IOWR	thREG(IOWR)	tIWHRGH	0	

Item	Symbol	IEEE Symbol	Min <sup>1</sup>	Max <sup>1</sup>
IOIS16 Delay Falling from Address	tdfIOIS16(ADR)	tAVISL		35
IOIS16 Delay Rising from Address	tdrIOIS16(ADR)	tAVISH		35

<sup>1</sup>All times are in nanoseconds.

**Note:** The maximum load on -INPACK and IOIS16 is 1 LSTTL with 50pF total load.

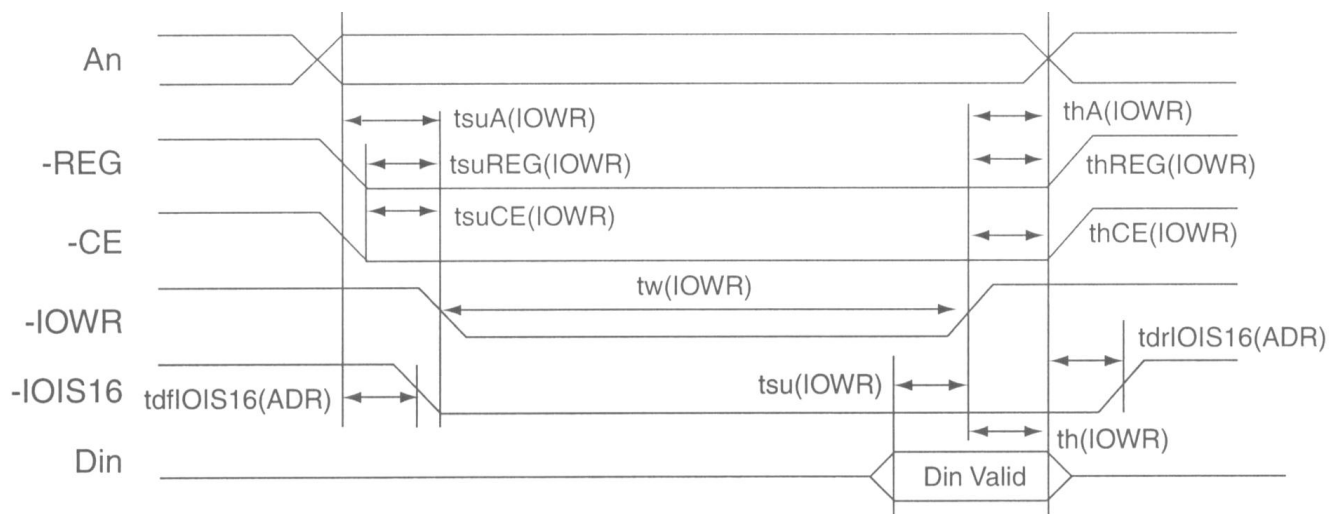

Figure 7. I/O Write Timing Diagram

### 4.14 True IDE PIO Mode Read/Write Timing

The timing diagram for True IDE mode of operation in this section is drawn using the conventions in the ATA-4 specification. Signals are shown with their asserted state as high regardless of whether the signal is actually negative or positive true. Consequently, the -IORD, the -IOWR and the -IOCS16 signals are shown in the diagram inverted from their electrical states on the bus.

Item	Mode 0	Mode 1	Mode 2	Mode 3	Mode 4	Mode 5	Mode 6
t0	Cycle time (min)	600	383	240	180	120	80
t1	Address Valid to -IORD/-IOWR setup (min)	70	50	30	30	25	10
t2	-IORD/-IOWR (min)	165	125	100	80	70	55
t2	-IORD/-IOWR (min) Register (8 bit)	290	290	290	80	70	55
t2i	-IORD/-IOWR recovery time (min)	-	-	-	70	25	20
t3	-IOWR data setup (min)	60	45	30	30	20	15
t4	-IOWR data hold (min)	30	20	15	10	10	5
5	-IORD data setup (min)	50	35	20	20	20	10
t6	-IORD data hold (min)	5	5	5	5	5	5

	Item	Mode 0	Mode 1	Mode 2	Mode 3	Mode 4	Mode 5	Mode 6
t6Z	-IORD data tristate (max)	30	30	30	30	30	20	20
t7	Address valid to -IOCS16 assertion (max)	90	50	40	n/a	n/a	n/a	n/a
t8	Address valid to -IOCS16 released (max)	60	45	30	n/a	n/a	n/a	n/a
t9	-IORD/-IOWR to address valid hold	20	15	10	10	10	10	10
tRD	Read Data Valid to IORDY active (min), if IORDY initially low after tA	0	0	0	0	0	0	0
tA	IORDY Setup time	35	35	35	35	35	na5	na5
tB	IORDY Pulse Width (max)	1250	1250	1250	1250	1250	na5	na5
tC	IORDY assertion to release (max)	5	5	5	5	5	na5	na5

**Notes:** All timings are in nanoseconds. The maximum load on -IOCS16 is 1 LSTTL with a 50 pF (40pF below 120nsec Cycle Time) total load. All waveforms in the following waveform are shown with the asserted state high. The negative true signal appears inverted on the bus relative to the diagram.

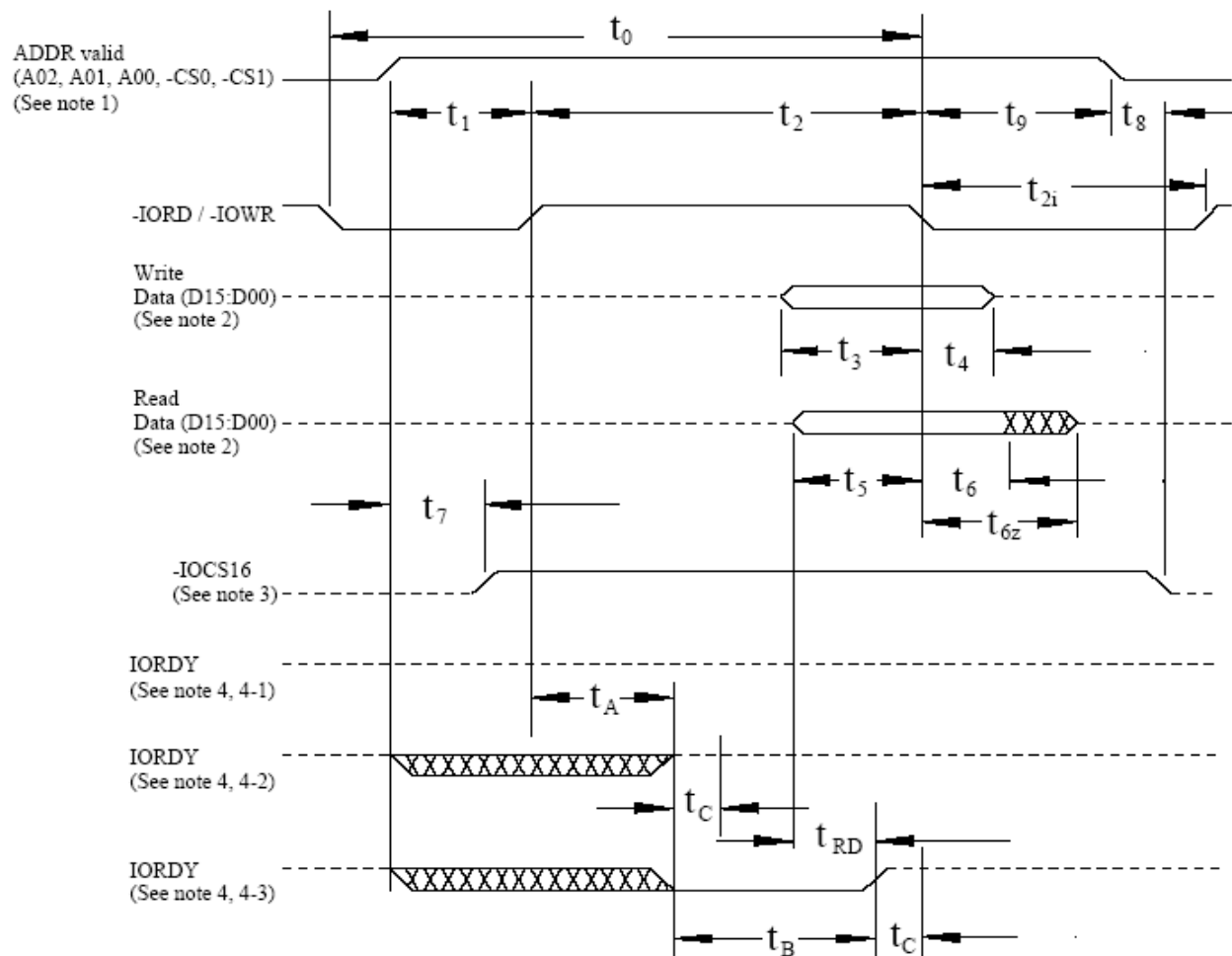

Notes:

- (1) Device address consists of -CS0, -CS1, and A[02::00]
- (2) Data consists of D[15::00] (16-bit) or D[07::00] (8 bit)
- (3) -IOCS16 is shown for PIO modes 0, 1 and 2. For other modes, this signal is ignored.
- (4) The negation of IORDY by the device is used to extend the PIO cycle. The determination of whether the cycle is to be extended is made by the host after -IORD or -IOWR. The assertion and negation of IORDY is described in the following three cases:
  - (4-1) Device never negates IORDY: No wait is generated.
  - (4-2) Device starts to drive IORDY low before  $t_A$ , but causes IORDY to be asserted before  $t_A$ : No wait generated.
  - (4-3) Device drives IORDY low before  $t_A$ : wait generated. The cycle completes after IORDY is reasserted. For cycles where a wait is generated and -IORD is asserted, the device shall place read data on D15-D00 for  $t_{RD}$  before causing IORDY to be asserted.

Figure 8. True IDE PIO Mode Read/Write Timing Diagram

## 4.15 True IDE Multiword DMA Mode Read/Write Timing

The timing diagram for True IDE DMA mode of operation in this section is drawn using the conventions in the ATA-4 specification. Signals are shown with their asserted state as high regardless of whether the signal is actually negative or positive true. Consequently, the -IORD, the -IOWR and the -IOCS16 signals are shown in the diagram inverted from their electrical states on the bus.



**Figure 9. True IDE Multiword DMA Mode Read/Write Timing Diagram**

## 5.0 Card Configuration

The Delkin CompactFlash cards are identified by appropriate information in the Card Information Structure (CIS). The following registers are used to coordinate the I/O spaces and the Interrupt level of the cards that are located in the system. In addition, these registers provide a method for accessing status information about the Delkin CompactFlash cards that may be used to arbitrate between multiple interrupt sources on the same interrupt level or to replace status information that appears on dedicated pins in memory cards that have alternate use in I/O cards.

### 5.1 Delkin Card Configuration

#### Register and Memory Space Decoding

-CE2	-CE1	-REG	-OE	-WE	A10	A9	A8-A4	A3	A2	A1	A0	Selected Space
1	1	X	X	X	X	X	XX	X	X	X	X	Standby
X	0	0	0	1	0	1	XX	X	X	X	0	Configuration Register Read
1	0	1	0	1	X	X	XX	X	X	X	X	Common Memory Read (8 bit D7-D0)
0	1	1	0	1	X	X	XX	X	X	X	X	Common Memory Read (8 bit D15-D8)
0	0	1	0	1	X	X	XX	X	X	X	0	Common Memory Read (16 bit D15-D0)
X	0	0	1	0	0	1	XX	X	X	X	0	Configuration Register Write
1	0	1	1	0	X	X	XX	X	X	X	X	Common Memory Write (8 bit D7-D0)
0	1	1	1	0	X	X	XX	X	X	X	X	Common Memory Write (8 bit D15-D8)
0	0	1	1	0	X	X	XX	X	X	X	0	Common Memory Write (16 bit D15-D0)

-CE2	-CE1	-REG	-OE	-WE	A10	A9	A8-A4	A3	A2	A1	A0	Selected Space
X	0	0	0	1	0	0	XX	X	X	X	0	Card Information Structure Read
1	0	0	1	0	0	0	XX	X	X	X	0	Invalid Access (CIS Write)
1	0	0	0	1	X	X	XX	X	X	X	1	Invalid Access (Odd Attribute Read)
1	0	0	1	0	X	X	XX	X	X	X	1	Invalid Access (Odd Attribute Write)
0	1	0	0	1	X	X	XX	X	X	X	X	Invalid Access (Odd Attribute Read)
0	1	0	1	0	X	X	XX	X	X	X	X	Invalid Access (Odd Attribute Write)

### Configuration Register Decoding

-CE2	-CE1	-REG	-OE	-WE	A10	A9	A8-A4	A3	A2	A1	A0	Selected Register
X	0	0	0	1	0	1	00	0	0	0	0	Configuration Option Reg Read
X	0	0	1	0	0	1	00	0	0	0	0	Configuration Option Reg Write
X	0	0	0	1	0	1	00	0	0	1	0	Card Status Register Read
X	0	0	1	0	0	1	00	0	0	1	0	Card Status Register Write
X	0	0	0	1	0	1	00	0	1	0	0	Pin Replacement Register Read
X	0	0	1	0	0	1	00	0	1	0	0	Pin Replacement Register Write
X	0	0	0	1	0	1	00	0	1	1	0	Socket and Copy Register Read

-CE2	-CE1	-REG	-OE	-WE	A10	A9	A8-A4	A3	A2	A1	A0	Selected Register
X	0	0	1	0	0	1	00	0	1	1	0	Socket and Copy Register Write

**Note:** The location of the card configuration registers should always be read from the CIS location 0000H to 0198H. No writes should be performed to the CompactFlash card attribute memory except to the card configuration register address. All other attribute memory locations are reserved.

## 5.2 Attribute Memory Function

Attribute memory is a space where CompactFlash card identification and configuration information are stored, and is limited to 8-bit wide accesses only at even addresses. The card configuration registers are also located here.

For the Attribute Memory function, signals –REG and –OE must be active and –WE inactive during the cycle.

As in the Main Memory Read functions, the signals –CE1 and –CE2 control the Even Byte and Odd Byte address, but only the Even Byte data is valid during the Attribute Memory access.

### Attribute Memory Function

Function Mode	-REG	-CE2	-CE1	A10	A9	A0	-OE	-WE	D15-D8	D7-D0
Standby Mode	X	VIH	VIH	X	X	X	X	X	High Z	High Z
Read Byte Access CIS ROM (8 bits)	VIL	VIH	VIL	VIL	VIL	VIL	VIL	VIH	High Z	Even Byte
Write Byte Access CIS (8 bits) (Invalid)	VIL	VIH	VIL	VIL	VIL	VIL	VIH	VIL	Don't Care	Even Byte
Read Byte Access Configuration (8 bits)	VIL	VIH	VIL	VIL	VIH	VIL	VIL	VIH	High Z	Even Byte
Write Byte Access Configuration (8 bits)	VIL	VIH	VIL	VIL	VIH	VIL	VIH	VIL	Don't Care	Even Byte
Read Word Access CIS (16 bits)	VIL	VIL	VIL	VIL	VIL	X	VIL	VIH	Not Valid	Even Byte
Write Word Access CIS (16 bits)	VIL	VIL	VIL	VIL	VIL	X	VIH	VIL	Don't Care	Even Byte

Function Mode	-REG	-CE2	-CE1	A10	A9	A0	-OE	-WE	D15-D8	D7-D0
Read Word Access Configuration (16 bits)	VIL	VIL	VIL	VIL	VIH	X	VIL	VIH	Not Valid	Even Byte
Write Word Access Configuration (16 bits)	VIL	VIL	VIL	VIL	VIH	X	VIH	VIL	Don't Care	Even Byte

**Note:** The  $\text{-CE}$  signal or both the  $\text{-OE}$  and the  $\text{-WE}$  signal must be de-asserted between consecutive cycle operations.

### 5.3 Configuration Option Register (Address 200H in Attribute Memory)

The Configuration Option Register is used to configure the interface, address decoding and interrupt and to issue a soft reset to the CompactFlash card.

Operation	D7	D6	D5	D4	D3	D2	D1	D0
R/W	SRESET	LevIREQ	Conf5	Conf4	Conf3	Conf2	Conf1	Conf0

SRESET	Soft Reset – Setting this bit to one (1), waiting the minimum reset width time and returning to zero (0) places the CompactFlash card in the Reset state. Setting this bit to one (1) is equivalent to assertion of the +RESET signal except that the SRESET bit is not cleared. Returning this bit to zero (0) leaves the CompactFlash card in the same un-configured Reset state as following power-up and hardware reset. This bit is set to zero (0) by power-up and hardware reset. Using the PCMCIA Soft Reset is considered a hard Reset by the ATA Commands. Contrast with Soft Reset in the Device Control register.
LevIREQ	This bit is set to one (1) when Level Mode Interrupt is selected, and zero (0) when Pulse mode is selected. Set to zero (0) by Reset.
Conf5-Conf0	Configuration Index. Set to zero (0) by reset. It's used to select operation mode of the CompactFlash card as shown below.

**Note:** Conf5 and Conf4 are reserved and must be written as zero (0).

#### Card Configurations

Conf5	Conf4	Conf3	Conf2	Conf1	Conf0	Disk Card Mode
0	0	0	0	0	0	Memory Mapped

0	0	0	0	0	1	I/O Mapped, any 16 Byte system decoded boundary
0	0	0	0	1	0	I/O Mapped, 1F0H-1F7H/3F6H-3F7H
0	0	0	0	1	1	I/O Mapped, 170H-177H/376H-377H

## 5.4 Card Configuration and Status Register (Address 200H in Attribute Memory)

The Card Configuration and Status Register contain information about the card's condition.

### Card Configuration and Status Register Organization

Operation	D7	D6	D5	D4	D3	D2	D1	D0
Read	Changed	SigChg	IOIS8	-XE	0	PwrDwn	Int	0
Write	0	SigChg	IOIS8	-XE	0	PwrDwn	0	0

Changed	Indicates that one or both of the Pin Replacement register CRdy or CWPort bits are set to one (1). When the Changed bit is set, Pin 46 (-STSCHG) is held low if the SigChg bit is a one (1) and the CompactFlash card is configured for the I/O interface.
SigChg	This bit is set and reset by the host to enable and disable a state-change "signal" from the Status Register, the Changed bit control pin 46 the Changed Status signal. If no state change signal is desired, this bit should be set to zero (0) and pin 46 (-STSCHG) signal will be held high while the CompactFlash card is configured for I/O.
IOIS8	The host sets this bit to a one (1) if the CompactFlash card is to be configured in an 8-bit I/O mode. The CompactFlash card is always configured for both 8-bit and 16-bit I/O, so this bit is ignored.
-XE	This bit is set and reset by the host to disable and enable Power Level 1 commands in CF+ cards. If the value is 0, Power Level 1 commands are enabled; if it is 1, Power Level 1 commands are disabled. Default value at power on or after reset is 0. The host may read the value of this bit to determine whether Power Level 1 commands are currently enabled. For CompactFlash cards that do not support Power Level 1, this bit has value 0 and is not writeable.
PwrDwn	This bit indicates whether the host requests the CompactFlash card to be in the power saving or active mode. When the bit is one (1), the CompactFlash card enters a power down mode. When zero (0), the host is requesting the CompactFlash card enter the active mode. The PCMICA Rdy/-Bsy value becomes BUSY when this bit is changed. Rfy/-Bsy will not become Ready until the power state requested has been entered. The CompactFlash card

	automatically powers down when it is idle and powers back-up when it receives a command.
Int	This bit represents the internal state of the interrupt request. This value is available whether or not I/O interface has been configured. This signal remains true until the condition which caused the interrupt request has been serviced. If interrupts are disabled by the –IEN bit in the Device Control Register, this bit is a zero (0).

## 5.5 Pin Replacement Register (Address 200H in Attribute Memory)

Operation	D7	D6	D5	D4	D3	D2	D1	D0
Read	0	0	CRdy/-Bsy	CWPort	1	1	Rdy/-Bsy	0
Write	0	0	CRdy/-Bsy	CWport	0	0	MRdy/-Bsy	X

CRdy/-Bsy	This bit is set to one (1) when the bit Rdy/-Bsy changes state. This bit can also be written by the host.
CWPort	This bit is set to one (1) when the RWPport changes state of the Rdy/-Bsy signal. This bit may be used to determine the state of the Ready/-Busy as this pin has been reallocated for use as Interrupt Request on an I/O card. When written, this bit acts as a mask for writing the corresponding bit CRdy/-Bsy.
MRdy/-Bsy	This bit acts as a mask for writing the corresponding CRdy/-Bsy.
X	This bit is ignored by the CompactFlash card.

### Pin Replacement Changed Bit/Mask Bit Values

Initial Value of (C) Status	Written By Host		Final “C” Bit	Comments
	“C” Bit	“M” Bit		
0	X	0	0	Unchanged
1	X	0	1	Unchanged
X	0	1	0	Cleared by Host
X	1	1	1	Set by Host

## 5.6 Socket and Copy Register (Address 200H in Attribute Memory)

This register contains additional configuration information. This register is always written by the system before writing the card's Configuration Index Register.

### Socket and Copy Register Organization

Operation	D7	D6	D5	D4	D3	D2	D1	D0
Read	Reserved	0	0	0	0	0	0	0
Write	0	0	0	0	X	X	X	X

Reserved	This bit is reserved for future standardization. This bit must be set to zero (0) by the software when the register is written.
Drive #	This bit indicates the drive number of the for twin card configuration. Twin card configuration is currently not supported.
X	The socket number is ignored by the CompactFlash card.

## 6.0 Transfer Functions

The following sections describe transfer functions for:

- Input/Output
- Common Memory
- True IDE Mode I/O

### 6.1 Input/Output

The Input/Output (I/O) transfer to or from the CompactFlash card can be either 8 or 16-bits. When a 16-bit accessible port is addressed, the signal  $\text{-IOIS16}$  Signal is asserted by the CompactFlash card. Otherwise, the  $\text{-IOIS16}$  signal is de-asserted. When a 16-bit transfer is attempted, and the  $\text{-IOIS16}$  signal is not asserted by the CompactFlash card, the system must generate a pair of 8-bit references to access the word's Even Byte and Odd Byte. The CompactFlash card permits both 8 and 16-bit accesses to all its I/O addresses, so  $\text{-IOIS16}$  is asserted for all addresses to which the CompactFlash card responds.

#### I/O Function

Function Code	-REG	-CE2	-CE1	A0	-IORD	-IOWR	D15-D8	D7-D0
Standby Mode	X	VIH	VIH	X	X	X	High Z	High Z
Byte Input Access (8 bits)	VIL	VIH	VIL	VIL	VIL	VIH	High Z	Even Byte
	VIL	VIH	VIL	VIH	VIL	VIH	High Z	Odd Byte
Byte Output Access (8 bits)	VIL	VIH	VIL	VIL	VIH	VIL	Don't Care	Even Byte
	VIL	VIH	VIL	VIH	VIH	VIL	Don't Care	Odd Byte
Word Input Access (16 bits)	VIL	VIL	VIL	VIL	VIL	VIH	Odd Byte	Don't Care
Word Output Access (16 bits)	VIL	VIL	VIL	VIL	VIH	VIL	Odd Byte	Even Byte
I/O Read Inhibit	VIH	X	X	X	VIL	VIH	Don't Care	Even Byte
I/O Write Inhibit	VIH	X	X	X	VIH	VIL	High Z	High Z
High Byte Input Only (8 bits)	VIL	VIL	VIH	X	VIL	VIH	Odd Byte	High Z
High Byte Output	VIL	VIL	VIH	X	VIH	VIL	Odd	Don't

Function Code	-REG	-CE2	-CE1	A0	-IORD	-IOWR	D15-D8	D7-D0
Only (8 bits)							Byte	Care

## 6.2 Common Memory

The Common Memory Transfer to or from the CompactFlash card can be either 8 or 16-bits.

The CompactFlash card permits both 8 and 16-bit accesses to all of its Common Memory Addresses.

### Common Memory Function

Function Code	-REG	-CE2	-CE1	A0	-OE	-WE	D15-D8	D7-D0
Standby Mode	X	VIH	VIH	X	X	X	High Z	High Z
Byte Read Access (8 bits)	VIH	VIH	VIL	VIL	VIL	VIH	High Z	Even Byte
	VIH	VIH	VIL	VIH	VIL	VIH	High Z	Odd Byte
Byte Write Access (8 bits)	VIH	VIH	VIL	VIL	VIH	VIL	Don't Care	Even Byte
	VIH	VIH	VIL	VIH	VIH	VIL	Don't Care	Odd Byte
Word Read Access (16 bits)	VIH	VIL	VIL	X	VIL	VIH	Odd Byte	Even Byte
Word Write Access (16 bits)	VIH	VIL	VIL	X	VIH	VIL	Odd Byte	Even Byte
High Byte Read Only (8 bits)	VIH	VIL	VIH	X	VIL	VIH	Odd Byte	High Z
High Byte Write Only (8 bits)	VIH	VIL	VIH	X	VIH	VIL	Odd Byte	Don't Care

## 6.3 True IDE Mode I/O

The CompactFlash card can be configured in a True IDE mode of operation. The CompactFlash card is configured in this mode only when the -OE input is grounded by the host during the power of to power on cycle. In this True ICE mode the PCMCIA protocol and configuration are disabled and only I/O operations to the Task File and Data register are allowed. In this mode no Memory or Attribute registers are accessible to the host. CompactFlash cards permit 8-bit data accesses if the user issues a Set Feature Command to put the device in 8-bit mode.

**Note:** Removing and reinstalling the CompactFlash card while the host computer's power is on will reconfigure the CompactFlash to PC Card ATA mode from the original True IDE mode. To configure the CompactFlash card in True IDE mode, the 50-pin socket must be power cycled with the CompactFlash card inserted and the  $\text{-OE}$  (output enable) asserted.

### True IDE Mode I/O Function

Function Code	-CS1	-CS0	A0-A2	-DMACK	-IORD	-IOWR	D15-D8	D7-D0
Invalid Modes	L	L	X	X	X	X	Undefined In/Out	Undefined In/Out
	L	X	X	L	L	X	Undefined Out	Undefined Out
	L	X	X	L	X	L	Undefined In	Undefined In
	X	L	X	L	L	X	Undefined Out	Undefined Out
	X	L	X	L	X	L	Undefined In	Undefined In
Standby Mode	H	H	X	H	X	X	High Z	High Z
Task File Write	H	L	1-7h	H	H	L	Don't Care	Data In
Task File Read	H	L	1-7h	H	L	H	High Z	Data Out
PIO Data Register Write	H	L	0	H	H	L	Odd-Byte In	Even-Byte In
DMA Data Register Write	H	H	X	L	H	L	Odd-Byte In	Even-Byte In
PIO Data Register Read	H	L	0	H	L	H	Odd-Byte Out	Even-Byte Out
DMA Data Register Read	H	H	X	L	L	H	Odd-Byte Out	Even-Byte Out
Control Register Write	L	H	6h	H	H	L	Don't Care	Control In
Alt Status Read	L	H	6h	H	L	H	High Z	Status Out
Drive Address1	L	H	7h	H	L	H	High Z	Data Out

**Notes:** 1) Implemented for backward compatibility. Bit D7 of the register shall remain High Z to prevent conflict with any floppy disk controller at the same address. The host software should not rely on the contents of this register.

## 7.0 Software Interface

### 7.1 CF-ATA Drive Register Set Definition and Protocol

The CompactFlash cards can be configured as a high performance I/O device through:

1. Standard PC-ATA disk I/O address spaces 1F0H-1F7H, 3F6H-7F7H (primary); 170H-177H, 376H-377H (secondary) with IRQ 14 (or other available IRQ)
2. Any system decoded 16 Byte I/O block using any available IRQ
3. Memory space

The communication to or from the CompactFlash card is done using the Task File registers which provide all the necessary register for control and status information. The PCMICA interface connects peripherals to the host using four register mapping methods.

#### I/O Configurations

Standard Configurations			
Config Index	I/O or Memory	Address	Description
0	I/O	0H-FH, 400H-7FFH	Memory Mapped
1	I/O	XX0H-XXFH	I/O Mapped 16 Contiguous Registers
2	I/O	1F0H-1F7H, 3F6H-3F7H	Primary I/O Mapped
3	I/O	170H-177H, 376H-377H	Secondary I/O Mapped

### 7.2 I/O Primary and Secondary Address Configurations

#### Primary and Secondary I/O Decoding

-REG	A9-A4	A3	A2	A1	A0	-IORD=0	-IOWR=0	Note
0	1F(17)H	0	0	0	0	Even RD Data	Even WR Data	1,2
0	1F(17)H	0	0	0	1	Error Register	Features	1,2
0	1F(17)H	0	0	1	0	Sector Count	Sector Count	
0	1F(17)H	0	0	1	1	Sector No.	Sector No.	

-REG	A9-A4	A3	A2	A1	A0	-IORD=0	-IOWR=0	Note
0	1F(17)H	0	1	0	0	Cylinder Low	Cylinder Low	
0	1F(17)H	0	1	0	1	Cylinder High	Cylinder High	
0	1F(17)H	0	1	1	0	Select Card/Head	Select Card/Head	
0	1F(17)H	0	1	1	1	Status	Command	
0	3F(37)H	0	1	1	0	Alt Status	Device Control	
0	3F(37)H	0	1	1	1	Drive Address	Reserved	

1. Register 0 is accessed with  $\text{--CE1}$  low and  $\text{--CE2}$  low (and  $\text{A0} = \text{Don't Care}$ ) as a word register on the combined Odd Data Bus and Even Data Bus (D15-D0). This register may also be accessed by a pair of byte accesses to the offset 0 with  $\text{--CE1}$  low and  $\text{--CE2}$  high. Note that the address space of this word register overlaps the address space of the Error and Feature byte-wide register which lie at offset 1. When accessed twice as byte register with  $\text{--CE1}$  low, the first byte to be accessed is the Even Byte of the word and the second byte accessed is the Odd Byte of the equivalent word access.
2. A byte access to register 0 with  $\text{--CE1}$  high and  $\text{--CE2}$  low accesses the error (read) or feature (write) register

**Note:** Address lines which are not indicated are ignored by the CompactFlash card for accessing all the registers in this table.

## 7.3 Contiguous I/O Mapped Addressing

When the system decodes a contiguous block of I/O registers to select the CompactFlash card, the registers are accessed in the block of I/O space decoded by the system as follows:

### Contiguous I/O Decoding

-REG	A3	A2	A1	A0	Offset	-IORD=0	-IOWR=0	Note
0	0	0	0	0	0	Even RD Data	Even WR Data	1
0	0	0	0	1	1	Error	Features	2
0	0	0	1	0	2	Sector Count	Sector Count	
0	0	0	1	1	3	Sector No.	Sector No.	
0	0	1	0	0	4	Cylinder Low	Cylinder Low	
0	0	1	0	1	5	Cylinder High	Cylinder High	
0	0	1	1	0	6	Select	Select Card/Head	

-REG	A3	A2	A1	A0	Offset	-IORD=0	-IOWR=0	Note
						Card/Head		
0	0	1	1	1	7	Status	Command	
0	1	0	0	0	8	Dup. Even RD Data	Dup. Even WR Data	2
0	1	0	0	1	9	Dup. odd RD Data	Dup. Even WR Data	2
0	1	1	0	1	D	Dup. Error	Dup. Features	2
0	1	1	1	0	E	Alt Status	Device Control	
0	1	1	1	1	F	Drive Address	Reserved	

## Notes for Continuous I/O Decoding Table

Code	Explanation
1	Register 0 is accessed with $\text{-CE1}$ low and $\text{-CE2}$ low (and $\text{A0} = \text{Don't care}$ ) as a word register on the combined Odd Data Bus and Even Data Bus (D15-D0). This register may also be accessed by a pair of byte accesses to the offset 0 with $\text{-DE1}$ low and $\text{-CE2}$ high. Note that the address space of this word register overlaps the address space of the error and feature byte-wide registers that lie at offset 1. When accessed twice as byte register with $\text{-Ce1}$ low, the first byte access to be accessed is the Even Byte of the word and the second byte accessed is the Odd Byte of the equivalent word access. A byte access to register 0 with $\text{-CE1}$ high and $\text{-CE2}$ low accesses the error (read) or feature (write) register.
2	<ol style="list-style-type: none"> <li>1. Register at offset 8, 9 and D are non-overlapping duplicates of the register at offset 0 and 1.</li> <li>2. Register 8 is equivalent to register 0, while register 9 accesses the Odd Byte. Therefore, if the registers are byte accessed in the order 9 then 8 the data will be transferred Odd Byte then Even Byte.</li> </ol>

Repeated byte accesses to register 8 or 0 will access consecutive (Even then Odd) Bytes from the data buffer. Repeated word accesses to register 8, 9, or 0 will access consecutive words from the data buffer. Repeated byte accesses to register 9 are not supported. However, repeated alternating byte accesses to register 8 then 9 will access consecutive (Even then Odd) Bytes from the data buffer. Byte accesses to register 9 access only the Odd Byte of the data.

**Note:** Address lines which are not indicated are ignored by the CompactFlash card for accessing all the registers in this table.

## 7.4 Memory Mapped Addressing

When the CompactFlash card registers are accessed via memory references, the registers appear in the common memory space window: 0-2KByte as follows:

### Memory Mapped Decoding

-REG	A10	A9-A4	A3	A2	A1	A0	Offset	-IORD=0	-IOWR=0	Note
1	0	X	0	0	0	0	0	Even RD Data	Even WR Data	1
1	0	X	0	0	0	1	1	Error	Features	2
1	0	X	0	0	1	0	2	Sector Count	Sector Count	
1	0	X	0	0	1	1	3	Sector No.	Sector No.	
1	0	X	0	1	0	0	4	Cylinder Low	Cylinder Low	
1	0	X	0	1	0	1	5	Cylinder High	Cylinder High	
1	0	X	0	1	1	0	6	Select Card/Head	Select Card/Head	
1	0	X	0	1	1	1	7	Status	Command	
1	0	X	1	0	0	0	8	Dup. Even RD Data	Dup. Even WR Data	2
1	0	X	1	0	0	1	9	Dup. odd RD Data	Dup. Even WR Data	2
1	0	X	1	1	0	1	D	Dup. Error	Dup. Features	2
1	0	X	1	1	1	0	E	Alt Status	Device Control	
1	0	X	1	1	1	1	F	Drive Address	Reserved	
1	1	X	X	X	X	0	8	Even RD Data	Even WR Data	3
1	1	X	X	X	X	1	9	Odd RD Data	Odd WR Data	3

### Notes for Memory Mapped Decoding Table

Code	Explanation
1	<p>Register 0 is accessed with <math>\text{-CE1}</math> low and <math>\text{-CE2}</math> low as a word register on the combined Odd Data Bus and Even Data Bus (D15-D0). This register may also be accessed by a pair of byte accesses to the offset 0 with <math>\text{-CE1}</math> low and <math>\text{-CE2}</math> high. Note that the address space of this word register overlaps the address space of the Error and Features byte-wide registers that lie at offset 1. When accessed twice as byte register with <math>\text{-CE1}</math> low, the first byte to be accessed is the Even Byte if the word and the second byte accessed is the Odd Byte if the equivalent word access.</p> <p>A byte access to address 0 with <math>\text{-CE1}</math> high and <math>\text{-CE2}</math> low accesses the error (read)</p>

Notes for Memory Mapped Decoding Table	
Code	Explanation
	or feature (write) register.
2	<p>Registers at offset 8, 9 and D are non-overlapping duplicates of the register at offset 0 and 1.</p> <p>Register 8 is equivalent to register 0, while register 9 accesses the Odd Byte. Therefore, if the registers are byte accessed in the order 9 then 8 the data will be transferred Odd Byte then Even Byte.</p> <p>Repeated byte accesses to register 8 or 0 will access consecutive (Even then Odd) Bytes from the data buffer. Repeated word accesses to register 8, 9 or 0 will access consecutive words from the buffer. Repeated byte accesses to register 9 are not supported. However, repeated alternating byte accesses to 8 then 9 will access consecutive (Even then Odd) Bytes from the data buffer. Byte accesses to register 9 access only the Odd Byte of the data.</p>
3	<p>Accesses to even addresses between 400H and 7FFH access register 8. Accesses to odd addresses between 400H and 7FFH access register 9. This 1 KByte memory window to the data register is provided so that hosts can perform memory to memory block moves to the data register when the register lies in memory space.</p> <p>Some hosts, such as the X86 processors, must increment both the source and destination addresses when executing the memory to memory block move instruction. Some PCMCIA socket adapters also have auto incrementing address logic embedded within them. This address window allows these hosts and adapters to function efficiently.</p> <p>Note that this entire window accesses the Data register FIFO and does not allow random access to the data buffer within the CompactFlash card.</p> <p>A word access to address at offset 8 will provide even data on the low-order byte of the data bus, along with odd data at offset 9 on the high-order byte of the data bus.</p>

## 7.5 True IDE Mode Addressing

When the CompactFlash card is configured in the True IDE Mode, the I/O decoding is as follows:

### True IDE Mode I/O Decoding

-CS1	-CS0	A2	A1	A0	-DMACK	-IORD=0	-IOWR=0	Note
1	0	0	0	0	1	PIO RD Data	PIO WR Data	8 or 16 bit
1	1	X	X	X	0	DMA RD Data	DMA WR Data	16 bit

-CS1	-CS0	A2	A1	A0	-DMACK	-IORD=0	-IOWR=0	Note
1	0	0	0	1	1	Error Register	Features	8 bit
1	0	0	1	0	1	Sector Count	Sector Count	8 bit
1	0	0	1	1	1	Sector No.	Sector No.	8 bit
1	0	1	0	0	1	Cylinder Low	Cylinder Low	8 bit
1	0	1	0	1	1	Cylinder High	Cylinder High	8 bit
1	0	1	1	0	1	Select Card/Head	Select Card/Head	8 bit
1	0	1	1	1	1	Status	Command	8 bit
0	1	1	1	0	1	Alt Status	Device Control	8 bit

## 7.6 CF-ATA Registers

The following section describes the hardware registers used by the host software to issue commands to the CompactFlash card. These registers are often collectively referred to as the “Task File”.

**Note:** In accordance with the PCMCIA specification: each of the registers below which is located at an odd offset address may be accessed at its normal address and also the corresponding even address (normal address -1) using data bus lines (D15-D8) when  $-\text{CE1}$  is high and  $-\text{CE2}$  is low unless  $-\text{IOIS16}$  is high (not asserted) and an I/O cycle is being performed.

In the True IDE mode of operation, the size of the transfer is based solely on the register being addressed. All registers are 8 bit only except for the Data Register, which is normally 16 bits, but can be programmed to use 8 bit transfers for Non-DMA operations through the use of the Set Features command. The data register is also 8 bits during a portion of the Read Long and Write Long commands, which exist solely for historical reasons and should not be used.

### 7.6.1 Data Register (Address – 1F0H[170H]; Offset 0,8,9)

The Data register is a 16 bit register, and it is used to transfer data blocks between the CompactFlash card data buffer and the host. This register overlaps the Error register.

The table below describes the combinations of data register access and is provided to assist in understanding the overlapped Data register and Error/Feature register rather than to attempt to define general PCMCIA word and byte access modes and operations. See the PCMCIA PC Card Standard for definitions of the Card Accessing Modes for I/O and Memory Cycles.

**Note:** Because of the overlapped registers, access to the 1F1H, 171H or offset 1 are not defined for word ( $-\text{CE2}=0$  and  $-\text{CE1}=0$ ) operations. These accesses are treated as accesses

to the Word Data register. The duplicated registers at offset 8, 9 and Dh have no restrictions on the operations that can be performed by the socket.

Data Register Memory and I/O Modes	-CE2	-CE1	A0	-REG	Offset	Data Bus
Word Data Register	0	0	X	-1	0,8,9	D15-D0
Even Data Register	1	0	0	-1	0,8	D7-D0
Odd Data Register	1	0	1	-1	9	D7-D0
Odd Data Register	0	1	X	-1	8,9	D15-D8
Error / Feature Register	1	0	1	-1	1, Dh	D7-D0
Error / Feature Register	0	1	X	-1	1	D15-D8
Error / Feature Register	0	0	X	-1	Dh	D15-D8
PIO Word Data Register	1	0	0	1	0	D15-D0
DMA Word Data Register	1	1	X	0	X	D15-D0
DMA Word Data Register (Selected Using Set Features Command)	1	0	0	1	0	D7-D0

**Notes:** 1) -REG signal is mode dependent. Signal shall be 0 for I/O mode and 1 for Memory Mode.

### 7.6.2 Error Register (Address – 1F1H [171H]; Offset 1, 0DH Read Only)

This register contains additional information about the source of an error when an error is indicated in bit 0 of the Status register. The bits are defined as follows:

D7	D6	D5	D4	D3	D2	D1	D0
BBK	UNC	0	IDFN	0	ABRT	0	AMNF

This register is also accessed on data bits D15-D8 during a write operation to offset 0 with –CE2 low and –CE1 high.

Bit 7 (BBK)	This bit is set when a Bad Block is detected.
Bit 6 (UNC)	This bit is set when an Uncorrectable Error is encountered.
Bit 5	This bit is 0.
Bit 4 (IDNF)	The requested sector ID is in error or cannot be found.
Bit 3	This bit is 0.
Bit 2 (Abort)	This bit is set if the command has been aborted because of a CompactFlash card status condition: (Not Ready, Write Fault, etc.) or when an invalid command has been issued.
Bit 1	This bit is 0.
Bit 0 (AMNF)	This bit is set in case of a general error.

### 7.6.3 Feature Register (Address – 1F1H[171H]; Offset 1, 0DH Write Only)

This register provides information regarding features of the CompactFlash card that the host can utilize.

This register is also accessed on data bits D15-D8 during a write operation to Offset 0 with –CE2 low and –CE1 high.

### 7.6.4 Sector Number (LBA 7-0) Register (Address – 1F3H[173H]; Offset 3)

This register contains the starting sector number or bits 7-0 of the Logical Block Address (LBA) for any Compact-Flash card data access for the subsequent command.

### 7.6.5 Cylinder Low (LBA 15-8) Register (Address – 1F4H[174H]; Offset 4)

This register contains the low order 8 bits of the starting cylinder address or bits 15-8 of the Logical Block Address.

### 7.6.6 Cylinder High (LBA 23-16) Register (Address – 1F5H[175H]; Offset 5)

This register contains the high order bits of the starting cylinder address or bits 23-16 of the Logical Block Address.

### 7.6.7 Drive/Head (LBA 27-24) Register (Address 1F6H[176H]; Offset 6)

The Drive/Head register is used to select the drive and head. It is also used to select LBA addressing instead of cylinder/head/sector addressing. The bits are defined as follows:

### 7.6.8 Drive/Head (LBA 27-24) Register (Address 1F6H[176H]; Offset 6)

The Drive/Head register is used to select the drive and head. It is also used to select LBA addressing instead of cylinder/head/sector addressing. The bits are defined as follows:

D7	D6	D5	D4	D3	D2	D1	D0
1	LBA	1	DRV	HS3	HS2	HS1	HS0

Bit 7	This bit is set to 1.
Bit 6	<p>LBA is a flag to select either Cylinder/Head/Sector (CHS) or Logical Block Address Mode (LBA). When LBA=0, Cylinder/Head/Sector mode is selected. When LBA=1, Logical Block Address is selected. In Logical Block mode, the Logical Block Address is interpreted as follows:</p> <ul style="list-style-type: none"> <li>• LBA7-LBA0: Sector Number register D7-D0.</li> <li>• LBA15-LBA8: Cylinder Low register D7-D0.</li> <li>• LBA23-LBA16: Cylinder High register D7-D0</li> <li>• LBA27-LBA24: Drive/Head register bits HS3-HS0.</li> </ul>
Bit 5	This bit is set to 1.
Bit 4 (DRV)	DRV is the drive number. When DRV=0, drive (card) 0 is selected. When DRV=1, drive (card) 1 is selected. The CompactFlash card is set to be Card 0 or 1 using the copy field (Drive #) of the PCMCIA Socket & Copy configuration register.
Bit 3 (HS3)	When operating in Cylinder, Head, Sector mode, this is bit 3 of the head number. It is Bit 27 in the Logical Block Address mode.
Bit 2 (HS2)	When operating in Cylinder, Head, Sector mode, this is bit 2 of the head number. It is Bit 26 in the Logical Block Address mode.
Bit 1 (HS1)	When operating in Cylinder, Head, Sector mode, this is bit 1 of the head number. It is Bit 25 in the Logical Block Address mode.
Bit 0 (HS0)	When operating in Cylinder, Head, Sector mode, this is bit 0 of the head number. It is Bit 24 in the Logical Block Address mode.

### 7.6.9 Status & Alternate Status Registers (Address 1F7H[177H]&3F6H[376H]; Offsets 7 & E)

These register return the CompactFlash card status when read by the host. Reading the Status register does clear a pending interrupt while reading the Auxiliary Status register does not. The meaning of the status bits are described as follows:

D7	D6	D5	D4	D3	D2	D1	D0
BUSY	RDY	DWF	DSC	DRQ	CORR	0	ERR

Bit 7 (BUSY)	The busy bit is set when the CompactFlash card has access to the command buffer and registers and the host is locked out from accessing the command register and buffer. No other bits in this register are valid when this bit is set to a 1. During the data transfer of DMA commands, the Card shall not assert DMARQ unless either the BUSY bit, the DRQ bit, or both are set to one.
Bit 6 (RDY)	RDY indicates whether the device is capable of performing CompactFlash card operations. This bit is cleared at power up and remains cleared until the CompactFlash card is ready to accept a command.
Bit 5 (DWF)	This bit, if set, indicates a write fault has occurred.
Bit 4 (DSC)	This bit is set when the CompactFlash card is ready.
Bit 3 (DRQ)	The Data Request is set when the CompactFlash card requires that information be transferred either to or from the host through the Data register. During the data transfer of DMA commands, the card shall not assert DMARQ unless the BUSY bit, the DRQ bit, or both, are set to one.
Bit 2 (CORR)	This bit is set when a Correctable data error has been encountered and the data has been corrected. This condition does not terminate a multi-sector read operation.
Bit 1 (IDX)	This bit is always set to 0.
Bit 0 (ERR)	This bit is set when the previous command has ended in some type of error. The bits in the Error register contain additional information describing the error. It is recommended that media access commands such as Read Sectors and Write Sectors that end with an error condition should have the address of the first sector in error in the command block register.

### 7.6.10 Device Control Register (Address – 3F6H[376H]; Offset E)

This register is used to control the CompactFlash card interrupt request and to issue an ATA soft reset to the card. This register can be written even if the device is BUSY. The bits are defined as follows:

D7	D6	D5	D4	D3	D2	D1	D0
X	X	X	X	1	SW Rst	-IEn	0

Bit 7	This bit is an X (don't care).
Bit 6	This bit is an X (don't care).
Bit 5	This bit is an X (don't care).
Bit 4	This bit is an X (don't care).
Bit 3	This bit is ignored by the CompactFlash card.
Bit 2 (SW Rst)	This bit is set to 1 in order to force the CompactFlash card to perform an ATA Disk controller Soft Reset operation. This does not change the PCMCIA Card Configuration registers as a hardware Reset does. The card remains in Reset until this bit is reset to "0".
Bit 1 (-IEn)	The Interrupt Enable bit enables interrupts when the bit is 0. When the bit is 1, interrupts from the CompactFlash card are disabled. This bit also controls the Int bit in the Configuration and Status register. This bit is set to 0 at power on and Reset.
Bit 0	This bit is ignored by the CompactFlash.

### 7.6.11 Card (Drive) Address Register (Address – 3F7H[377H]; Offset F)

This register is provided for compatibility with the ATA disk drive interface. It is recommended that this register not be mapped into the host's I/O space because of potential conflicts on Bit 7. The bits are defined as follows:

D7	D6	D5	D4	D3	D2	D1	D0
X	-WTG	-HS3	-HS2	-HS1	-HS0	-nDS1	-nDS0

Bit 7 This bit is *don't care*.

**Implementation Note:**

Conflicts may occur on the host data bus when this bit is provided by a Floppy Disk Controller operating at the same addresses as the CompactFlash card. The following are some possible solutions to this problem for the PCMCIA implementation:

1. Locate the CompactFlash card at a non-conflicting address, i.e. Secondary address (377) or in an independently decoded Address Space when a Floppy Disk Controller is located at the Primary Addresses.
2. Do not install a Floppy Disk and a CompactFlash card in the system at the same time.
3. Implement a socket adapter which can be programmed to (conditionally) tri-state D7 of I/O address 3F7H/377H when a CompactFlash card is installed and conversely to tri-state D6-D0 of I/O address 3F7H/377H when a floppy controller is installed.
4. Do not use CompactFlash card's Drive Address register. This may be accomplished by either A) if possible, program the host adapter to enable only I/O addresses 1F0H-1F7H, 3F6H (or 170H-177H, 176H) to the CompactFlash card or B) If provided, use an additional Primary/Secondary configuration in the CompactFlash card which does not respond to accesses to I/O locations 3F7H and 377H. With either of these implementations, the host software must not attempt to use information in the Drive Address register.

Bit 6 (-WTG)	This bit is 0 when a write operation is in progress, otherwise, it is 1.
Bit 5 (-HS3)	This bit is the negation of bit 3 in the Drive/Head register.
Bit 4 (-HS2)	This bit is the negation of bit 2 in the Drive/Head register.
Bit 3 (-HS1)	This bit is the negation of bit 1 in the Drive/Head register.
Bit 2 (-HS0)	This bit is the negation of bit 0 in the Drive/Head register.
Bit 1 (-nDS1)	This bit is 0 when drive 1 is active and selected.
Bit 0 (-nDS0)	This bit is 0 when drive 0 is active and selected.

**7.7 CF-ATA Command Description**

This section defines the software requirements and the format of the commands the host sends to the CompactFlash cards. Commands are issued to the CompactFlash card by

loading the required registers in the command block with the supplied parameters, and then writing the command code to the Command register. The manner in which a command is accepted varies. These are three classes of command acceptance, all dependent on the host not issuing commands unless the CompactFlash card is not busy (BSY=0).

### 7.7.1 CF-ATA Command set

The following table summarizes the CF-ATA command set with the paragraphs that follow describing the individual commands and the tasks file for each.

Class	COMMAND	Code	FR	SC	SN	CY	DH	LBA
1	Check Power Mode	E5h or 98h	-	-	-	-	D	-
1	Execute Drive Diagnostic	90h	-	-	-	-	D	-
1	Erase Sector(s)	C0h	-	Y	Y	Y	Y	Y
1	Flush Cache	E7h	-	-	-	-	D	-
2	Format Track	50h	-	Y	-	Y	Y	Y
1	Identify Device	ECh	-	-	-	-	D	-
1	Idle	E3h or 97h	-	Y	-	-	D	-
1	Idle Immediate	E1h or 95h	-	-	-	-	D	-
1	Initialize Drive Parameters	91h	-	Y	-	-	Y	-
1	Key Management Structure Read	B9 Feature 0-127	C	C	C	C	D C	-
1	Key Management Read Keying Material	B9 Feature 80	C	C	C	C	D C	-
2	Key Management Change Key Management Value	B9 Feature 81	C	C	C	C	D C	-
1	NOP	00h	-	-	-	-	D	-
1	Read Buffer	E4h	-	-	-	-	D	-
1	Read DMA	C8h	-	Y	Y	Y	Y	Y
1	Read Long Sector	22h or 23h	-	-	Y	Y	Y	Y

Class	COMMAND	Code	FR	SC	SN	CY	DH	LBA
1	Read Multiple	C4h	-	Y	Y	Y	Y	Y
1	Read Sector(s)	20h or 21h	-	Y	Y	Y	Y	Y
1	Read Verify Sector(s)	40h or 41h	-	Y	Y	Y	Y	Y
1	Recalibrate	1Xh	-	-	-	-	D	-
1	Request Sense	03h	-	-	-	-	D	-
1	Security Disable Password	F6h	-	-	-	-	D	-
1	Security Erase Prepare	F3h	-	-	-	-	D	-
1	Security Erase Unit	F4h	-	-	-	-	D	-
1	Security Freeze Lock	F5h	-	-	-	-	D	-
1	Security Set Password	F1h	-	-	-	-	D	-
1	Security Unlock	F2h	-	-	-	-	D	-
1	Seek	7Xh	-	-	Y	Y	Y	Y
1	Set Features	EFh	Y	-	-	-	D	-
1	Set Multiple Mode	C6h	-	Y	-	-	D	-
1	Set Sleep Mode	E6h or 99h	-	-	-	-	D	-
1	Standby	E2h or 96h	-	-	-	-	D	-
1	Standby Immediate	E0h or 94h	-	-	-	-	D	-
1	Translate Sector	87h	-	Y	Y	Y	Y	Y
1	Wear Level	F5h	-	-	-	-	Y	-
2	Write Buffer	E8h	-	-	-	-	D	-
2	Write DMA	CAh	-	Y	Y	Y	Y	Y

Class	COMMAND	Code	FR	SC	SN	CY	DH	LBA
2	Write Long Sector	32h or 33h	-	-	Y	Y	Y	Y
3	Write Multiple	C5h	-	Y	Y	Y	Y	Y
3	Write Multiple w/o Erase	CDh	-	Y	Y	Y	Y	Y
2	Write Sector(s)	30h or 31h	-	Y	Y	Y	Y	Y
2	Write Sector(s) w/o Erase	38h	-	Y	Y	Y	Y	Y
3	Write Verify	3Ch	-	Y	Y	Y	Y	Y

1. FR = Features Register
2. SC = Sector Count Register
3. SN = Sector Number Register
4. CY = Cylinder Register
5. DH = Card/Drive/Head Register
6. LBA = Logical Block Address Mode Supported (see command description for use).
7. Y = The register contains a valid parameter for this command.
8. For the Drive/Head Register:
  - Y – both the CompactFlash card and head parameters are used;
  - D – only the CompactFlash card parameter is valid and not the head parameter.

**7.7.2 Check Power Mode – 98H or E5H**

Bit →	7	6	5	4	3	2	1	0
<b>Command (7)</b>	98h or E5h							
<b>C/D/H (6)</b>	X		Drive		X			
<b>Cyl High (5)</b>					X			
<b>Cyl Low (4)</b>					X			
<b>Sec Num (3)</b>					X			
<b>Sec Cnt (2)</b>					X			
<b>Feature (1)</b>					X			

- This command checks the power mode.

- Because Delkin's CompactFlash card can recover from sleep in 200ms, idle mode is never enabled.
- CompactFlash card sets BSY, sets the Sector Count Register to 00H, Clears BSY and generates an interrupt.

### 7.7.3 Execute Drive Diagnostics – 90H

Bit →	7	6	5	4	3	2	1	0
<b>Command (7)</b>	90H							
<b>C/D/H (6)</b>	X			Drive	X			
<b>Cyl High (5)</b>	X							
<b>Cyl Low (4)</b>	X							
<b>Sec Num (3)</b>	X							
<b>Sec Cnt (2)</b>	X							
<b>Feature (1)</b>	X							

This command performs the internal diagnostic test implemented by the CompactFlash card.

If in PCMCIA configuration this command runs only on the CompactFlash card which is addressed by the Drive/Head register when the diagnostic command is issued. This is because PCMCIA card interface does not allow for direct inter-drive communication (such as the ATA PDIAG and DASP signals). If in True IDE mode the Drive bit is ignored and the diagnostic command is executed by both the master and the slave with the master responding with status for both devices.

The Diagnostic codes shown below are returned in the Error register at the end of the command.

#### Diagnostic Codes

Code	Error Type
01H	No Error Detected
02H	Formatter Device Error
03H	Sector Buffer Error
04H	ECC Circuitry Error
05H	Controlling Microprocessor Error
8XH	Slave Error in True IDE mode

**7.7.4 Erase Sector(s) – C0H**

Bit ->	7	6	5	4	3	2	1	0
<b>Command (7)</b>	C0H							
<b>C/D/H (6)</b>	1	LBA	1	Drive	Head (LBA 27-24)			
<b>Cyl High (5)</b>	Cylinder High (LBA 23-16)							
<b>Cyl Low (4)</b>	Cylinder Low (LBA 15-8)							
<b>Sec Num (3)</b>	Sector Number (LBA 7-0)							
<b>Sec Cnt (2)</b>	Sector Count							
<b>Feature (1)</b>	X							

This command is used to pre-erase and condition data sectors in advance of a Write without Erase or Write Multiple without Erase command. There is no data transfer associated with this command but a Write Fault error status can occur.

**7.7.5 Flush Cache – E7h**

Bit ->	7	6	5	4	3	2	1	0
<b>Command (7)</b>	E7h							
<b>C/D/H (6)</b>	X		Drive		X			
<b>Cyl High (5)</b>	X							
<b>Cyl Low (4)</b>	X							
<b>Sec Num (3)</b>	X							
<b>Sec Cnt (2)</b>	X							
<b>Feature (1)</b>	X							

This command causes the card to complete writing data from its cache. The card returns status with RDY=1 and DSC=1 after the data in the write cache buffer is written to the media. If the Compact Flash Card does not support the Flush Cache command, the Compact Flash Card shall return command aborted.

**7.7.6 Format Track – 50H**

Bit →	7	6	5	4	3	2	1	0
<b>Command (7)</b>	50H							
<b>C/D/H (6)</b>	1	LBA	1	Drive	Head (LBA 27-24)			
<b>Cyl High (5)</b>	Cylinder High (LBA 23-16)							
<b>Cyl Low (4)</b>	Cylinder Low (LBA 15-8)							
<b>Sec Num (3)</b>	X (LBA 7-0)							
<b>Sec Cnt (2)</b>	Count (LBA mode only)							
<b>Feature (1)</b>	X							

This command writes the desired head and cylinder of the selected drive with a vendor unique data pattern (typically FFH or 00H). To remain host backward compatible, the CompactFlash card expects a sector buffer of data from the host to follow the command with the same protocol as the Write Sector(s) command although the information in the buffer is not used by the CompactFlash card. If LBA=1 then the number of sectors to format is taken from Sec Cnt register (0=256). The use of this command is not recommended.

**7.7.7 Identify Drive - ECH**

Bit →	7	6	5	4	3	2	1	0
<b>Command (7)</b>	ECH							
<b>C/D/H (6)</b>	X	X	X	Drive	X			
<b>Cyl High (5)</b>	X							
<b>Cyl Low (4)</b>	X							
<b>Sec Num (3)</b>	X							
<b>Sec Cnt (2)</b>	X							
<b>Feature (1)</b>	X							

The Identify Drive command enables the host to receive parameter information from the CompactFlash card. This command has the same protocol as the Read Sector(s) command.

**Identify Drive Information**

Word Address	Default Value	Total Bytes	Data Field Type Information
0	848Ah	2	General configuration - signature for the CompactFlash Card
	0XXX	2	General configuration – Bit Significant with ATA-4 definitions
1	XXXXh	2	Default number of cylinders
2	0000h	2	Reserved
3	00XXh	2	Default number of heads
4	0000h	2	Obsolete
5	0000h	2	Obsolete
6	XXXXh	2	Default number of sectors per track
7-8	XXXXh	4	Number of sectors per card (Word 7 = MSW, Word 8 = LSW)
9	XXXXh	2	Obsolete
10-19	aaaa	20	Serial number in ASCII (Right Justified)
20	0000h	2	Obsolete
21	0000h	2	Obsolete
22	0004h	2	Number of ECC bytes passed on Read/Write Long Commands
23-26	aaaa	8	Firmware revision in ASCII. Big Endian Byte Order in Word
27-46	aaaa	40	Model number in ASCII (Left Justified) Big Endian Byte Order in Word
47	XXXXh	2	Maximum number of sectors on Read/Write Multiple command
48	0000h	2	Reserved
49	XX00h	2	Capabilities
50	0000h	2	Reserved
51	0X00h	2	PIO data transfer cycle timing mode
52	0000h	2	Obsolete
53	000Xh	2	Field Validity
54	XXXXh	2	Current numbers of cylinders
55	XXXXh	2	Current numbers of heads
56	XXXXh	2	Current sectors per track
57-58	XXXXh	4	Current capacity in sectors (LBAs)(Word 57 = LSW, Word 58 = MSW)
59	01XXh	2	Multiple sector setting
60-61	XXXXh	4	Total number of sectors addressable in LBA Mode
62	0000h	2	Reserved
63	0X0Xh	2	Multiword DMA transfer. In PCMCIA mode this value shall be 0h
64	00XXh	2	Advanced PIO modes supported

Word Address	Default Value	Total Bytes	Data Field Type Information
65	XXXXh	2	Minimum Multiword DMA transfer cycle time per word. In PCMCIA mode this value shall be 0h
66	XXXXh	2	Recommended Multiword DMA transfer cycle time. In PCMCIA mode this value shall be 0h
67	XXXXh	2	Minimum PIO transfer cycle time without flow control
68	XXXXh	2	Minimum PIO transfer cycle time with IORDY flow control
69-127	0000h	116	Reserved
128	XXXXh	2	Security status
129-159	0000h	64	Vendor unique bytes
160-255	0000h	172	Reserved

### 7.7.7.1 General Configuration

This field indicates the general characteristics of the device. When Word 0 of the Identify drive information is 848Ah then the device is a CompactFlash Card and complies with the CFA specification and CFA command set. It is recommended that PCMCIA modes of operation report only the 848Ah value as they are always intended as removable devices.

### 7.7.7.2 Default Number of Cylinders

This field contains the number of translated cylinders in the default translation mode. This value will be the same as the number of cylinders.

### 7.7.7.3 Default Number of Heads

This field contains the number of translated heads in the default translation mode.

### 7.7.7.4 Default Number of Sectors per Track

This field contains the number of sectors per track in the default translation mode.

### 7.7.7.5 Number of Sectors per Card

This field contains the number of sectors per CompactFlash card. This double word value is also the first invalid address in LBA translation mode.

### 7.7.7.6 Serial Number

This field contains the serial number for this CompactFlash Card and is right justified and padded with spaces (20h).

### 7.7.7.7 ECC Count

This field defines the number of ECC bytes used on each sector in the Read and Write Long commands. This value shall be set to 0004h.

### 7.7.7.8 Firmware Revision

This field contains the revision of the firmware for this product.

### 7.7.7.9 Model Number

This field contains the model number for this product and is left justified and padded with spaces (20H).

### 7.7.7.10 Read/Write Multiple Sector Count

Bits 15-8 shall be the recommended value of 80h or the permitted value of 00h. Bits 7-0 of this word define the maximum number of sectors per block that the CompactFlash Card supports for Read/Write Multiple commands.

### 7.7.7.11 Capabilities

Bit 13: Standby Timer Set to 0, forces sleep mode when host is inactive.

Bit 11: IORDY Support Set to 0 indicates that this device may support IORDY operation.

Bit 9: LBA Support Set to 1, Delkin's CompactFlash supports LBA mode addressing.

Bit 8: DMA Support If bit 8 = 1 then Read DMA and Write DMA commands are supported.

If bit 8 = 0 then Read/Write DMA commands are not currently permitted on CF cards.

### 7.7.7.12 PIO Data transfer Cycle Timing Mode

The PIO transfer timing for each CompactFlash Card falls into modes that have unique parametric timing specifications. The value returned in Bits 15-8 shall be 00h for mode 0, 01h for mode 1, or 02h for mode 2. Values 03h through FFh are reserved.

### 7.7.7.13 Translation Parameters Valid

Bit 0 shall be set to 1 indicating that words 54 to 58 are valid and reflect the current number of cylinders, heads, and sectors. If bit 1 of word 53 is set to 1, the values in words 64 through 70 are valid. If this bit is cleared to 0, the values reported in words 64-70 are not valid. Any CompactFlash Card that supports PIO mode 3 or above shall set bit 1 of word 53 to one and support the fields contained in words 64 through 70.

### 7.7.7.14 Current Number of Cylinders, Heads, Sectors/Track

These fields contain the current number of user addressable Cylinders, Heads, and Sectors/Track in the current translation mode.

### 7.7.7.15 Current Capacity

This field contains the product of the current cylinders times heads times sectors.

### 7.7.7.16 Multiple Sector Setting

Bits 15-9 are reserved and shall be set to 0.

Bit 8 shall be set to 1 indicating that the Multiple Sector Setting is valid.

Bits 7-0 are the current setting for the number of sectors that shall be transferred per interrupt on Read/Write Multiple commands.

### 7.7.7.17 Total Sectors Addressable in LBA Mode

This field contains the total number of user addressable sectors for the CompactFlash Card in LBA mode only.

### 7.7.7.18 Multiword DMA transfer

Bits 15 through 8 of word 63 of the Identify Device parameter information is defined as the Multiword

DMA mode selected field. If this field is supported, bit 1 of word 53 shall be set to one. This field is bit significant. Only one of bits may be set to one in this field by the CompactFlash Card to indicate the multiword DMA mode which is currently selected.

Of these bits, bits 15 through 11 are reserved. Bit 8, if set to one, indicates that Multiword DMA mode 0 has been selected. Bit 9, if set to one, indicates that Multiword DMA mode 1 has been selected. Bit 10, if set to one, indicates that Multiword DMA mode 2 has been selected.

Bits 7 through 0 of word 63 of the Identify Device parameter information is defined as the Multiword DMA data transfer supported field. If this field is supported, bit 1 of word 53 shall be set to one. This field is bit significant. Any number of bits may be set to one in this field by the CompactFlash Card to indicate the Multiword DMA modes it is capable of supporting.

Of these bits, bits 7 through 2 are reserved. Bit 0, if set to one, indicates that the CompactFlash Card supports Multiword DMA mode 0. Bit 1, if set to one, indicates that the CompactFlash Card supports Multiword DMA modes 1 and 0. Bit 2, if set to one, indicates that the CompactFlash Card supports Multiword DMA modes 2, 1 and 0.

### 7.7.7.19 Advanced PIO transfer modes supported

Bits 7 through 0 of word 64 of the Identify Device parameter information is defined as the advanced PIO data transfer supported field. If this field is supported, bit 1 of word 53 shall be set to one. This field is bit significant. Any number of bits may be set to one in this field by the CompactFlash Card to indicate the advanced PIO modes it is capable of supporting.

Of these bits, bits 7 through 2 are reserved. Bit 0, if set to one, indicates that the CompactFlash Card supports PIO mode 3. Bit 1, if set to one, indicates that the CompactFlash Card supports PIO mode 4.

### 7.7.7.20 Minimum Multiword DMA transfer cycle time

Word 65 of the parameter information of the Identify Device command is defined as the minimum Multiword DMA transfer cycle time. This field defines, in nanoseconds, the

minimum cycle time that, if used by the host, guarantees CompactFlash Card data integrity during the transfer.

If this field is supported, bit 1 of word 53 shall be set to one. The value in word 65 shall not be less than the minimum cycle time for the fastest DMA mode supported by the device. This field shall be supported by all CompactFlash Cards supporting DMA modes 1 and above.

If bit 1 of word 53 is set to one, but this field is not supported, the Card shall return a value of zero in this field.

#### **7.7.7.21 Recommended Multiword DMA transfer cycle time**

Word 66 of the parameter information of the Identify Device command is defined as the recommended Multiword DMA transfer cycle time. This field defines, in nanoseconds, the cycle time that, if used by the host, may optimize the data transfer from by reducing the probability that the CompactFlash Card will need to negate the DMARQ signal during the transfer of a sector.

If this field is supported, bit 1 of word 53 shall be set to one. The value in word 66 shall not be less than the value in word 65. This field shall be supported by all CompactFlash Cards supporting DMA modes 1 and above.

If bit 1 of word 53 is set to one, but this field is not supported, the Card shall return a value of zero in this field.

#### **7.7.7.22 Minimum PIO transfer cycle time without flow control**

Word 67 of the parameter information of the Identify Device command is defined as the minimum PIO transfer without flow control cycle time. This field defines, in nanoseconds, the minimum cycle time that, if used by the host, guarantees CompactFlash Card data integrity during the transfer, without utilization of flow control.

If this field is supported, Bit 1 of word 53 shall be set to one.

Any CompactFlash Card that supports PIO mode 3 or above shall support this field, and the value in word 67 shall not be less than the value reported in word 68.

If bit 1 of word 53 is set to one because a CompactFlash Card supports a field in words 64-70 other than this field and the CompactFlash Card does not support this field, the CompactFlash Card shall return a value of zero in this field.

#### **7.7.7.23 Minimum PIO transfer cycle time with IORDY**

Word 68 of the parameter information of the Identify Device command is defined as the minimum PIO transfer with IORDY flow control cycle time. This field defines, in nanoseconds, the minimum cycle time that the CompactFlash Card supports while performing data transfers while utilizing IORDY flow control. If this field is supported, Bit 1 of word 53 shall be set to one.

Any CompactFlash Card that supports PIO mode 3 or above shall support this field, and the value in word 68 shall be the fastest defined PIO mode supported by the CompactFlash Card.

If bit 1 of word 53 is set to one because a CompactFlash Card supports a field in words 64-70 other than this field and the CompactFlash Card does not support this field, the CompactFlash Card shall return a value of zero in this field.

#### 7.7.7.24 Security Status

Bit 8: Security Level:

- If set to 1, indicates that security mode is enabled and the security level is maximum.
- If set to 0 and security mode is enabled, indicates that the security level is high.

Bit 5: Enhanced security erase unit feature supported:

- If set to 1, indicates that the Enhanced security erase unit feature set is supported.

Bit 4: Expire:

- If set to 1, indicates that the security count has expired and Security Unlock and Security Erase Unit are command aborted until a power-on reset or hard reset.

Bit 3: Freeze:

- If set to 1, indicates that the security is Frozen.

Bit 2: Lock:

- If set to 1, indicates that the security is locked.

Bit 1: Enable/Disable:

- If set to 1, indicates that the security is enabled.
- If set to 0, indicates that the security is disabled.

Bit 0: Capability:

- If set to 1, indicates that CompactFlash Card supports security mode feature set.
- If set to 0, indicates that CompactFlash Card does not support security mode feature set.

**7.7.8 Idle – 97H or E3H**

Bit →	7	6	5	4	3	2	1	0
<b>Command (7)</b>	97H or E3H							
<b>C/D/H (6)</b>	X		Drive		X			
<b>Cyl High (5)</b>	X							
<b>Cyl Low (4)</b>	X							
<b>Sec Num (3)</b>	X							
<b>Sec Cnt (2)</b>	Timer Count (5 ms increments)							
<b>Feature (1)</b>	X							

This command causes the CompactFlash card to set BSY, enter the idle mode, clear BSY, and generate an interrupt. If the sector count is non-zero, it is interpreted as a timer count with each count being 5 milliseconds and the automatic power down mode is enabled. If the sector count is zero, the automatic power down mode is disabled. Note that this time base (5 ms) is different from the ATA specification.

**7.7.9 Idle Immediate – 95H or E1H**

Bit →	7	6	5	4	3	2	1	0
<b>Command (7)</b>	97H or E1H							
<b>C/D/H (6)</b>	X		Drive		X			
<b>Cyl High (5)</b>	X							
<b>Cyl Low (4)</b>	X							
<b>Sec Num (3)</b>	X							
<b>Sec Cnt (2)</b>	X							
<b>Feature (1)</b>	X							

This command causes the CompactFlash card to set BSY, enter the idle mode, clear BSY, and generate an interrupt.

**7.7.10 Initialize Drive Parameters – 91H**

Bit ->	7	6	5	4	3	2	1	0
<b>Command (7)</b>	91H							
<b>C/D/H (6)</b>	X	0	X	Drive	Max Head (no. of heads-1)			
<b>Cyl High (5)</b>	X							
<b>Cyl Low (4)</b>	X							
<b>Sec Num (3)</b>	X							
<b>Sec Cnt (2)</b>	Number of Sectors							
<b>Feature (1)</b>	X							

This command enables the host to set the number of sectors per track and the number of heads per cylinder. Only the Sector Count and the Card/Drive/Head register are used by this command.

**7.7.11 Key Management Structure Read – B9h (Feature: 0-127)**

Bit ->	7	6	5	4	3	2	1	0
<b>Command (7)</b>	B9h							
<b>C/D/H (6)</b>	Reserved (0)			Drive	Reserved (0)			
<b>Cyl High (5)</b>	C7-0							
<b>Cyl Low (4)</b>	C15-8							
<b>Sec Num (3)</b>	C23-16							
<b>Sec Cnt (2)</b>	C31-24							
<b>Feature (1)</b>	0	C38-32						

The KEY MANAGEMENT STRUCTURE READ command is optional, depending on the Key Management scheme in use.

This command returns a 512-byte Key Management data structure via PIO data-in transfer. The structure encodes device Key Management status defined by the Key

Management scheme in use. In some schemes, this structure may include a cryptographic response.

The values 39-bit value C38-0 is a random number picked by the host. It is used as a challenge value by some Key Management schemes. All 39-bit values are acceptable.

### 7.7.12 Key Management Read Keying Material - B9h (Feature: 80)

Bit ->	7	6	5	4	3	2	1	0
<b>Command (7)</b>	B9h							
<b>C/D/H (6)</b>	Reserved (0)			Drive	Reserved (0)			
<b>Cyl High (5)</b>	Reserved (0)							
<b>Cyl Low (4)</b>	Keying Material Sector Offset - High							
<b>Sec Num (3)</b>	Keying Material Sector Offset - Low							
<b>Sec Cnt (2)</b>	Keying Material Count							
<b>Feature (1)</b>	80h							

The KEY MANAGEMENT READ KEYING MATERIAL command is optional, depending on the Key Management scheme in use.

This command reads from 1 to 256 sectors as specified in the Sector Count register. A Sector Count of 0 requests 256 sectors. The transfer shall begin at the Sector Offset within the keying material specified in the 16 bit number comprised of the Sector Number and Cylinder Low registers. The size and format of the keying material is specific to the Key Management scheme in use.

If an uncorrectable error occurs reading the keying material, the Sector Number and Cylinder Low registers are left indicating the offset of the sector in error.

**7.7.13 Key Management Change Key Management Value – B9h (Feature: 81)**

Bit ->	7	6	5	4	3	2	1	0
<b>Command (7)</b>	B9h							
<b>C/D/H (6)</b>	Reserved (0)			Drive	Reserved (0)			
<b>Cyl High (5)</b>	B2h							
<b>Cyl Low (4)</b>	6Eh							
<b>Sec Num (3)</b>	Reserved (0)							
<b>Sec Cnt (2)</b>	Reserved (0)							
<b>Feature (1)</b>	81h							

The KEY MANAGEMENT CHANGE KEY MANAGEMENT VALUE command is optional, depending on the Key Management scheme in use.

This command causes the device to change a value found in the KEY MANAGEMENT READ KEY MANAGEMENT STRUCTURE response. The method is specific to the Key Management scheme in use. The special value B26Eh in the cylinder registers is checked by the card to make it less likely that the command was executed by mistake.

**7.7.14 NOP - 00h**

Bit ->	7	6	5	4	3	2	1	0
<b>Command (7)</b>	00h							
<b>C/D/H (6)</b>	X			Drive	X			
<b>Cyl High (5)</b>	X							
<b>Cyl Low (4)</b>	X							
<b>Sec Num (3)</b>	X							
<b>Sec Cnt (2)</b>	X							
<b>Feature (1)</b>	X							

This command always fails with the CompactFlash Card returning command aborted.

**7.7.15 Read Buffer – E4H**

Bit ->	7	6	5	4	3	2	1	0
<b>Command (7)</b>	E4H							
<b>C/D/H (6)</b>	X		Drive		X			
<b>Cyl High (5)</b>	X							
<b>Cyl Low (4)</b>	X							
<b>Sec Num (3)</b>	X							
<b>Sec Cnt (2)</b>	X							
<b>Feature (1)</b>	X							

The Read Buffer command enables the host to read current contents of the CompactFlash card's sector buffer. This command has the protocol as the Read Sector(s) command.

**7.7.16 Read DMA – C8h**

Bit ->	7	6	5	4	3	2	1	0
<b>Command (7)</b>	C8h							
<b>C/D/H (6)</b>	1	LBA	1	Drive	Head (LBA 27-24)			
<b>Cyl High (5)</b>	Cylinder High (LBA 23-16)							
<b>Cyl Low (4)</b>	Cylinder Low (LBA 15-8)							
<b>Sec Num (3)</b>	Sector Number (LBA 7-0)							
<b>Sec Cnt (2)</b>	Sector Count							
<b>Feature (1)</b>	X							

This command uses DMA mode to read from 1 to 256 sectors as specified in the Sector Count register. A sector count of 0, requests 256 sectors. The transfer begins at the sector specified in the Sector Number Register. When this command is issued the CompactFlash Card sets BSY, puts all or part of the sector of data in the buffer. The Card is then permitted, although not required, to set DRQ, clear BSY. The Card asserts DMAREQ while data is available to be transferred. The Card asserts DMAREQ while data is available to be transferred. The host then reads the (512 \* sector-count) bytes of data from the Card using DMA. While DMAREQ is asserted by the Card, the Host asserts -

DMACK while it is ready to transfer data by DMA and asserts -IORD once for each 16 bit word to be transferred to the Host.

Interrupts are not generated on every sector, but upon completion of the transfer of the entire number of sectors to be transferred or upon the occurrence of an unrecoverable error.

At command completion, the Command Block Registers contain the cylinder, head and sector number of the last sector read. If an error occurs, the read terminates at the sector where the error occurred. The Command Block Registers contain the cylinder, head, and sector number of the sector where the error occurred. The amount of data transferred is indeterminate.

When a Read DMA command is received by the Card and 8 bit transfer mode has been enabled by the Set Features command, the Card shall return the Aborted error.

### 7.7.17 Read Long Sector - 22h or 23h

Bit ->	7	6	5	4	3	2	1	0
<b>Command (7)</b>	22h or 23h							
<b>C/D/H (6)</b>	1	LBA	1	Drive	Head (LBA 27-24)			
<b>Cyl High (5)</b>	Cylinder High (LBA 23-16)							
<b>Cyl Low (4)</b>	Cylinder Low (LBA 15-8)							
<b>Sec Num (3)</b>	Sector Number (LBA 7-0)							
<b>Sec Cnt (2)</b>	X							
<b>Feature (1)</b>	X							

The Read Long command performs similarly to the Read Sector(s) command except that it returns 516 bytes of data instead of 512 bytes. During a Read Long command, the CompactFlash Card does not check the ECC bytes to determine if there has been a data error. Only single sector read long operations are supported. The transfer consists of 512 bytes of data transferred in word mode followed by 4 bytes of ECC data transferred in byte mode. This command has the same protocol as the Read Sector(s) command.

Use of this command is not recommended.

**7.7.18 Read Multiple – C4H**

Bit →	7	6	5	4	3	2	1	0
<b>Command (7)</b>	C4H							
<b>C/D/H (6)</b>	1	LBA	1	Drive	Head (LBA 27-24)			
<b>Cyl High (5)</b>	Cylinder High (LBA 23-16)							
<b>Cyl Low (4)</b>	Cylinder Low (LBA 15-8)							
<b>Sec Num (3)</b>	Sector Number (LBA 7-0)							
<b>Sec Cnt (2)</b>	Sector Count							
<b>Feature (1)</b>	X							

The Read Multiple command performs similarly to the Read Sectors command. Interrupts are not generated on every sector, but on the transfer of a block which contains the number of sectors defined by a Set Multiple command.

Command execution is identical to the Read Sectors operation except that the number of sectors defined by a Set Multiple command is transferred without intervening interrupts. DRQ qualification of the transfer is required only at the start of the data block, not on each sector.

The Block count of sectors to be transferred without intervening interrupts is programmed by the Set Multiple command, which must be executed prior to the Read Multiple command. When the Read Multiple command is issued, the Sector Count register contains the number of sectors (not the number of blocks or the block count) requested. If the number of requested sectors is not evenly divisible by the block count, as many full blocks as possible are transferred, followed by a final, partial block transfer. The partial block transfer is for  $n$  sectors, where

$$n = (\text{sector count}) \bmod (\text{block count}).$$

If the Read Multiple command is attempted before the Set Multiple Mode command has been executed or when Read Multiple commands are disabled, the Read Multiple operation is rejected with an Aborted Command error. Disk error encountered during Read Multiple commands are posted at the beginning of the block or partial block transfer, but DRQ is still set and the data transfer will take place as it normally would, including transfer of corrupted data, if any.

Interrupts are generated when DRQ is set at the beginning of each block or partial block. The error reporting is the same as that on a Read Sector(s) Command. This command reads from 1 to 256 sectors as specified in the Sector Count register. A sector count of 0, requests 256 sectors. The transfer begins at the sector specified in the Sector Number register.

At command completion, the Command Block register contain the cylinder, head and sector number of the last sector read.

If an error occurs, the read terminates at the sector where the error occurred. The Command Block registers contain the cylinder, head and sector number of the sector where the error occurred. The flawed data is pending in the sector buffer.

Subsequent blocks or partial blocks are transferred only if the error was a correctable data error. All other errors cause the command to stop after the transfer of the block which contained the error.

### 7.7.19 Read Sector(s) – 20H or 21H

Bit →	7	6	5	4	3	2	1	0
<b>Command (7)</b>	20H or 21H							
<b>C/D/H (6)</b>	1	LBA	1	Drive	Head (LBA 27-24)			
<b>Cyl High (5)</b>	Cylinder High (LBA 23-16)							
<b>Cyl Low (4)</b>	Cylinder Low (LBA 15-8)							
<b>Sec Num (3)</b>	Sector Number (LBA 7-0)							
<b>Sec Cnt (2)</b>	Sector Count							
<b>Feature (1)</b>	X							

This command reads from 1 to 256 sectors as specified in the Sector Count register. A sector count of 0, requests 256 sectors. The transfer begins at the sector specified in the Sector Number register. When this command is issued and after each sector of data (except the last one) has been read by the host, the CompactFlash card sets BSY, puts the sector of data in the buffer, set DRQ, clears BSY, and generates an interrupt. The host then reads the 512 Bytes of data from the buffer.

At command completion, the Command Block register contain cylinder, head, and sector number of the last sector read. If an error occurs, the read terminates at the sector where the error occurred. The Command Block register contain the cylinder, head and sector number of the sector where the error occurred. The flawed data is pending in the sector buffer.

**7.7.20 Read Verify Sector(s) – 40H or 41H**

Bit →	7	6	5	4	3	2	1	0
<b>Command (7)</b>	40H or 41H							
<b>C/D/H (6)</b>	1	LBA	1	Drive	Head (LBA 27-24)			
<b>Cyl High (5)</b>	Cylinder High (LBA 23-16)							
<b>Cyl Low (4)</b>	Cylinder Low (LBA 15-8)							
<b>Sec Num (3)</b>	Sector Number (LBA 7-0)							
<b>Sec Cnt (2)</b>	Sector Count							
<b>Feature (1)</b>	X							

This command is identical to the Read Sectors command, except that DRQ is never set and no data is transferred to the host. When the command is accepted, the CompactFlash card sets BSY.

When the requested sectors have been verified, the CompactFlash card clears BSY and generates an interrupt. Upon command completion, the Command Block registers contain the cylinder, head, and sector number of the last sector verified.

If an error occurs, the verification terminates at the sector where the error occurs. The Command Block registers contain the cylinder, head and sector number of the sector where the error occurred. The Sector Count register contains the number of sectors not yet verified.

**7.7.21 Recalibrate – 1XH**

Bit →	7	6	5	4	3	2	1	0
<b>Command (7)</b>	1XH							
<b>C/D/H (6)</b>	1	LBA	1	Drive	X			
<b>Cyl High (5)</b>	X							
<b>Cyl Low (4)</b>	X							
<b>Sec Num (3)</b>	X							
<b>Sec Cnt (2)</b>	X							
<b>Feature (1)</b>	X							

This command is effectively a NOP command to the CompactFlash card and is provided for compatibility purposes.

### 7.7.22 Request Sense – 03H

Bit →	7	6	5	4	3	2	1	0
<b>Command (7)</b>	03H							
<b>C/D/H (6)</b>	1	X	1	Drive			X	
<b>Cyl High (5)</b>					X			
<b>Cyl Low (4)</b>				X				
<b>Sec Num (3)</b>			X					
<b>Sec Cnt (2)</b>				X				
<b>Feature (1)</b>				X				

This command requests extended error information for the previous command. The following table defines the valid extended error codes for the CompactFlash Card Series product. The extended error code is returned to the host in the Error register.

#### Extended Error Codes

Extended Error Code	Description
00h	No Error Detected
01h	Self-Test OK (No Error)
09h	Miscellaneous Error
20h	Invalid Command
21h	Invalid Address (Requested Head or Sector Invalid)
2Fh	Address Overflow (Address Too Large)
35h, 36h	Supply or generated Voltage Out of Tolerance
11h	Uncorrectable ECC Error
18h	Corrected ECC Error

Extended Error Code	Description
05h, 30-34h, 37h, 3Eh	Self-Test or Diagnostic Failed
10h, 14h	ID Not Found
3Ah	Spare Sectors Exhausted
1Fh	Data Transfer Error / Aborted Command
0Ch, 38h, 3Bh, 3Ch, 3Fh	Corrupted Media Format
03h	Write / Erase Failed
22h	Power Level 1 Disabled

### 7.7.23 Security Disable Password - F6h

Bit ->	7	6	5	4	3	2	1	0
Command (7)	F6h							
C/D/H (6)	1	LBA	1	Drive	X			
Cyl High (5)	X							
Cyl Low (4)	X							
Sec Num (3)	X							
Sec Cnt (2)	X							
Feature (1)	X							

This command requests a transfer of a single sector of data from the host. The following table defines the content of this sector of information. If the password selected by word 0 matches the password previously saved by the device, the device disables the lock mode. This command does not change the Master password that may be reactivated later by setting a User password. Use of this command is not recommended by the CFA.

### Security Password Data Content

Word	Content
0	Control word Bit 0: identifier 0=compare User password 1=compare Master password Bit 1-15: Reserved
1-16	Password (32 bytes)
17-256	Reserved

### 7.7.24 Security Erase Prepare - F3h

Bit ->	7	6	5	4	3	2	1	0
Command (7)	F3h							
C/D/H (6)	1	LBA	1	Drive	X			
Cyl High (5)	X							
Cyl Low (4)	X							
Sec Num (3)	X							
Sec Cnt (2)	X							
Feature (1)	X							

This command shall be issued immediately before the Security Erase Unit command to enable device erasing and unlocking. This command prevents accidental erase of the CompactFlash Card. Use of this command is not recommended by the CFA.

**7.7.25 Security Erase Unit - F4h**

Bit ->	7	6	5	4	3	2	1	0
<b>Command (7)</b>	F4h							
<b>C/D/H (6)</b>	1	LBA	1	Drive	X			
<b>Cyl High (5)</b>	X							
<b>Cyl Low (4)</b>	X							
<b>Sec Num (3)</b>	X							
<b>Sec Cnt (2)</b>	X							
<b>Feature (1)</b>	X							

This command requests transfer of a single sector of data from the host. If the password does not match the password previously saved by the CompactFlash Card, the CompactFlash Card rejects the command with command aborted. The Security Erase Prepare command shall be completed immediately prior to the Security Erase Unit command. If the CompactFlash Card receives a Security Erase Unit command without an immediately prior Security Erase Prepare command, the CompactFlash Card command aborts the Security Erase Unit command. Use of this command is not recommended by the CFA.

**7.7.26 Security Freeze Lock - F5h**

Bit ->	7	6	5	4	3	2	1	0
<b>Command (7)</b>	F5h							
<b>C/D/H (6)</b>	1	LBA	1	Drive	X			
<b>Cyl High (5)</b>	X							
<b>Cyl Low (4)</b>	X							
<b>Sec Num (3)</b>	X							
<b>Sec Cnt (2)</b>	X							
<b>Feature (1)</b>	X							

The Security Freeze Lock command sets the CompactFlash Card to Frozen mode. After command completion, any other commands that update the CompactFlash Card Lock mode are rejected. Frozen mode is disabled by power off or hardware reset. If Security Freeze Lock is issued when the CompactFlash Card is in frozen mode, the command executes and the CompactFlash Card remains in frozen mode.

After command completion, the Sector Count Register shall be set to 0. Use of this command is not recommended by the CFA.

Commands disabled by Security Freeze Lock are:

- Security Set Password
- Security Unlock
- Security Disable Password
- Security Erase Unit

If security mode feature set is not supported, this command shall be handled as Wear Level command.

### 7.7.27 Security Set Password - F1h

Bit ->	7	6	5	4	3	2	1	0
<b>Command (7)</b>	F1h							
<b>C/D/H (6)</b>	1	LBA	1	Drive	X			
<b>Cyl High (5)</b>					X			
<b>Cyl Low (4)</b>					X			
<b>Sec Num (3)</b>					X			
<b>Sec Cnt (2)</b>					X			
<b>Feature (1)</b>					X			

This command requests a transfer of a single sector of data from the host. The data transferred controls the function of this command.

### 7.7.28 Security Unlock - F2h

Bit ->	7	6	5	4	3	2	1	0
<b>Command (7)</b>	F2h							
<b>C/D/H (6)</b>	1	LBA	1	Drive	X			
<b>Cyl High (5)</b>					X			
<b>Cyl Low (4)</b>					X			
<b>Sec Num (3)</b>					X			
<b>Sec Cnt (2)</b>					X			
<b>Feature (1)</b>					X			

This command requests transfer of a single sector of data from the host. If the identifier bit is set to Master and the device is in high security level, then the password supplied shall be compared with the stored Master password. If the device is in the maximum security level, then the unlock command shall be rejected. If the identifier bit is set to user, then the device compares the supplied password with the stored User password. If the password compare fails then the device returns command aborted to the host and decrements the unlock counter. This counter is initially set to five and is decremented for each password mismatch when Security Unlock is issued and the device is locked. Once this counter reaches zero, the Security Unlock and Security Erase Unit commands are command aborted until after a power-on reset or a hardware reset is received. Security Unlock commands issued when the device is unlocked have no effect on the unlock counter. Use of this command is not recommended by the CFA.

### 7.7.29 Seek – 7XH

Bit →	7	6	5	4	3	2	1	0
<b>Command (7)</b>	7XH							
<b>C/D/H (6)</b>	1	LBA	1	Drive	Head (LBA 27-24)			
<b>Cyl High (5)</b>	Cylinder High (LBA 23-16)							
<b>Cyl Low (4)</b>	Cylinder Low (LBA 15-8)							
<b>Sec Num (3)</b>	X (LBA 7-0)							
<b>Sec Cnt (2)</b>	X							
<b>Feature (1)</b>	X							

This command is effectively a NOP command to the CompactFlash card although it does perform a range check of cylinder and head or LBA address and returns an error if the address is out of range.

**7.7.30 Set Feature – EFH**

Bit →	7	6	5	4	3	2	1	0
<b>Command (7)</b>	EFH							
<b>C/D/H (6)</b>		X		Drive			X	
<b>Cyl High (5)</b>	X							
<b>Cyl Low (4)</b>	X							
<b>Sec Num (3)</b>	X							
<b>Sec Cnt (2)</b>	Config							
<b>Feature (1)</b>	Feature							

This command is used by the host to establish or select certain features. The following table defines all Features that are supported.

**Features Supported**

Feature	Operation
01h	Enable 8 bit data transfers.
02h	Enable Write Cache.
03h	Set transfer mode based on value in Sector Count register.
05h	Enable Advanced Power Management.
09h	Enable Extended Power operations.
0Ah	Enable Power Level 1 commands.
44h	Product specific ECC bytes apply on Read/Write Long commands.
55h	Disable Read Look Ahead.
66h	Disable Power on Reset (POR) establishment of defaults at Soft Reset.
69h	NOP - Accepted for backward compatibility.
81h	Disable 8 bit data transfer.
82h	Disable Write Cache.
85h	Disable Advanced Power Management.
89h	Disable Extended Power operations.
8Ah	Disable Power Level 1 commands.

Feature	Operation
96h	NOP - Accepted for backward compatibility.
97h	Accepted for backward compatibility. Use of this Feature is not
9Ah	Set the host current source capability. Allows tradeoff between current
AAh	Enable Read Look Ahead.
BBh	4 bytes of data apply on Read/Write Long commands.
CCh	Enable Power on Reset (POR) establishment of defaults at Soft Reset.

Features 01h and 81h are used to enable and clear 8 bit data transfer modes in True IDE Mode. If the 01h feature command is issued all data transfers shall occur on the low order D[7:0] data bus and the -IOIS16 signal shall not be asserted for data register accesses. The host shall not enable this feature for DMA transfers.

Features 02h and 82h allow the host to enable or disable write cache in CompactFlash Cards that implement write cache. When the subcommand disable write cache is issued, the CompactFlash Card shall initiate the sequence to flush cache to non-volatile memory before command completion.

Feature 03h allows the host to select the PIO or Multiword DMA transfer mode by specifying a value in the Sector Count register. The upper 5 bits define the type of transfer and the low order 3 bits encode the mode value. One PIO mode shall be selected at all times. For Cards which support DMA, one Multiword DMA mode shall be selected at all times. The host may change the selected modes by the Set Features command.

### 7.7.31 Set Multiple Mode – C6H

Bit →	7	6	5	4	3	2	1	0
<b>Command (7)</b>	C6H							
<b>C/D/H (6)</b>		X		Drive			X	
<b>Cyl High (5)</b>					X			
<b>Cyl Low (4)</b>				X				
<b>Sec Num (3)</b>			X					
<b>Sec Cnt (2)</b>	Sector Count							
<b>Feature (1)</b>				X				

This command enables the CompactFlash card to perform Read and Write Multiple operations and establishes the block count for these commands. The Sector Count

register is loaded with the number of sectors per block. Upon receipt of the command, the CompactFlash card sets BSY to 1 and checks the Sector Count register.

If the Sector Count register contains a valid value and the block count is supported, the value is loaded for all subsequent Read Multiple and Write Multiple commands and execution of those commands is enabled.

If a block count is not supported, an Aborted Command error is posted, and Read Multiple and Write Multiple commands are disabled. If the Sector Count register contains 0 when the command is issued,

Read and Write Multiple commands are disabled. At power on, or after a hardware or (unless disabled by a Set Feature command) software reset, the default mode is Read and Write Multiple disabled.

### 7.7.32 Set Sleep Mode – 99H or E6H

Bit →	7	6	5	4	3	2	1	0
<b>Command (7)</b>	99H or E6H							
<b>C/D/H (6)</b>		X		Drive			X	
<b>Cyl High (5)</b>					X			
<b>Cyl Low (4)</b>					X			
<b>Sec Num (3)</b>					X			
<b>Sec Cnt (2)</b>					X			
<b>Feature (1)</b>					X			

This command causes the CompactFlash card to set BSY, enter the Sleep mode, clear BSY and generate an interrupt. Recovery from sleep mode is accomplished by simply issuing another command (a reset is permitted but not required). Sleep mode is also entered when internal timers expire so the host does not need to issue this command except when it wishes to enter Sleep mode immediately. The default value for the timer is 5 milliseconds.

**7.7.33 Standby – 96H or E2H**

Bit →	7	6	5	4	3	2	1	0
<b>Command</b>	96H or E2H							
<b>C/D/H (6)</b>		X		Drive			X	
<b>Cyl High (5)</b>					X			
<b>Cyl Low (4)</b>					X			
<b>Sec Num (3)</b>					X			
<b>Sec Cnt (2)</b>					X			
<b>Feature (1)</b>					X			

**7.7.34 Standby – 94H or E0H**

Bit →	7	6	5	4	3	2	1	0
<b>Command</b>	94H or E0H							
<b>C/D/H (6)</b>		X		Drive			X	
<b>Cyl High (5)</b>					X			
<b>Cyl Low (4)</b>					X			
<b>Sec Num (3)</b>					X			
<b>Sec Cnt (2)</b>					X			
<b>Feature (1)</b>					X			

These commands cause the CompactFlash card to set BSY, enter the Sleep mode (which corresponds to the ATA “Standby” mode), clear BSY, and return the interrupt immediately. Recovery from sleep mode is accomplished by issuing another command (a reset is not required).

**7.7.35 Translate Sector – 87H**

Bit →	7	6	5	4	3	2	1	0
<b>Command</b>	87H							
<b>C/D/H (6)</b>	1	LBA	1	Drive	Head (LBA 27-24)			
<b>Cyl High (5)</b>	Cylinder High (LBA 23-16)							
<b>Cyl Low (4)</b>	Cylinder Low (LBA 15-8)							
<b>Sec Num (3)</b>	Sector Number (LBA 7-0)							
<b>Sec Cnt (2)</b>	X							
<b>Feature (1)</b>	X							

This command allows the host a method of determining the exact number of times a user sector has been erased and programmed. The controller responds with a 512 Byte buffer of information containing the desired cylinder, head and sector, including its Logical Address, and the Hot Count, if available, for that sector. The following table represents the information in the buffer. Please note that this command is unique to the CompactFlash card.

**Translate Sector Information**

Address	Information
00H-01H	Cylinder MSB (00), Cylinder LSB (01)
02H	Head
03H	Sector
04H-06H	LBA MSB (04) – LSB (06)
07H-12H	Reserved
13H	Erased Flag (FFH) = Erased; 00h = Not Erased
14H-17H	Reserved
18-1AH	Hot Count MSB (18) – LSB (1A) <sup>1</sup>
1BH-1FFH	Reserved

<sup>1</sup>Value of 0 indicates Hot Count is not supported

**7.7.36 Wear Level – F5H**

Bit ->	7	6	5	4	3	2	1	0
<b>Command (7)</b>	F5h							
<b>C/D/H (6)</b>	X	X	X	Drive	Flag			
<b>Cyl High (5)</b>	X							
<b>Cyl Low (4)</b>	X							
<b>Sec Num (3)</b>	X							
<b>Sec Cnt (2)</b>	Completion Status							
<b>Feature (1)</b>	X							

For the CompactFlash Cards that do not support security mode feature set, this command is effectively a NOP command and only implemented for backward compatibility. The Sector Count Register shall always be returned with a 00h indicating Wear Level is not needed. If the CompactFlash Card supports security mode feature set, this command shall be handled as Security Freeze Lock.

**7.7.37 Write Buffer – E8H**

Bit ->	7	6	5	4	3	2	1	0
<b>Command (7)</b>	E8h							
<b>C/D/H (6)</b>	X			Drive	X			
<b>Cyl High (5)</b>	X							
<b>Cyl Low (4)</b>	X							
<b>Sec Num (3)</b>	X							
<b>Sec Cnt (2)</b>	X							
<b>Feature (1)</b>	X							

The Write Buffer command enables the host to overwrite contents of the CompactFlash card's sector buffer with any data pattern desired. This command had the same protocol as the Write Sector(s) command and transfers 512 Bytes.

**7.7.38 Write DMA – CAh**

Bit ->	7	6	5	4	3	2	1	0
<b>Command (7)</b>	CAh							
<b>C/D/H (6)</b>	1	LBA	1	Drive	Head (LBA 27-24)			
<b>Cyl High (5)</b>	Cylinder High (LBA 23-16)							
<b>Cyl Low (4)</b>	Cylinder Low (LBA 15-8)							
<b>Sec Num (3)</b>	Sector Number (LBA 7-0)							
<b>Sec Cnt (2)</b>	Sector Count							
<b>Feature (1)</b>	X							

This command uses DMA mode to write from 1 to 256 sectors as specified in the Sector Count register. A sector count of 0, requests 256 sectors. The transfer begins at the sector specified in the Sector Number Register. When this command is issued the CompactFlash Card sets BSY, puts all or part of the sector of data in the buffer. The Card is then permitted, although not required, to set DRQ, clear BSY. The Card asserts DMAREQ while data is available to be transferred. The host then writes the (512 \* sector-count) bytes of data to the Card using DMA. While DMAREQ is asserted by the Card, the Host asserts -DMACK while it is ready to transfer data by DMA and asserts -LOWR once for each 16 bit word to be transferred from the Host.

Interrupts are not generated on every sector, but upon completion of the transfer of the entire number of sectors to be transferred or upon the occurrence of an unrecoverable error.

At command completion, the Command Block Registers contain the cylinder, head and sector number of the last sector read. If an error occurs, the read terminates at the sector where the error occurred. The Command Block Registers contain the cylinder, head, and sector number of the sector where the error occurred. The amount of data transferred is indeterminate.

When a Write DMA command is received by the Card and 8 bit transfer mode has been enabled by the Set Features command, the Card shall return the Aborted error.

**7.7.39 Write Long Sector – 32H or 33H**

Bit →	7	6	5	4	3	2	1	0
<b>Command (7)</b>	32H or 33H							
<b>C/D/H (6)</b>	1	LBA	1	Drive	Head (LBA 27-24)			
<b>Cyl High (5)</b>	Cylinder High (LBA 23-16)							
<b>Cyl Low (4)</b>	Cylinder Low (LBA 15-8)							
<b>Sec Num (3)</b>	Sector Number (LBA 7-0)							
<b>Sec Cnt (2)</b>	X							
<b>Feature (1)</b>	X							

This command is similar to the Write Sector(s) command except that it writes 516 Bytes instead of 512 Bytes. Only single sector Write Long operations are supported. The transfer consists of 512 Bytes of data transferred in Word-Mode followed by 4 Bytes of ECC transferred in Byte-Mode. Because of the unique nature of the solid-state CompactFlash card, the 4 Bytes of ECC transferred by the host may be used by the CompactFlash card. The CompactFlash card may discard these 4 Bytes and write the sector with valid ECC data. This command has the same protocol as the Write Sector(s) command.

**7.7.40 Write Multiple Command – C5H**

Bit →	7	6	5	4	3	2	1	0
<b>Command (7)</b>	C5H							
<b>C/D/H (6)</b>	1	LBA	1	Drive	Head			
<b>Cyl High (5)</b>	Cylinder High							
<b>Cyl Low (4)</b>	Cylinder Low							
<b>Sec Num (3)</b>	Sector Number							
<b>Sec Cnt (2)</b>	Sector Count							
<b>Feature (1)</b>	X							

This command is similar to the Write Sectors command. The CompactFlash card sets BSY within 400 ns of accepting the command. Interrupts are not presented on each sector but on the transfer of a block which contains the number of sectors defined by Set Multiple. Command execution is identical to the

Write Sectors operation except that the number of sectors defined by the Set Multiple command is transferred without intervening interrupts.

DRQ qualifications of the transfer is required only at the start of the data block, not on each sector. The block count of sectors to be transferred without intervening interrupts is programmed by the Set Multiple Mode command, which must be executed prior to the Write Multiple command.

When the Write Multiple command is issued, the Sector Count register contains the number of sectors (not the number of blocks or the block count) requested. If the number of the requested sectors is not evenly divisible by the sector/block, as many full blocks as possible are transferred, followed by a final, partial block transfer. The partial block transfer is for  $n$  sectors, where:

$$n = (\text{sector count}) \bmod (\text{block count}).$$

If the Write Multiple command is attempted before the Set Multiple Mode command has been executed or when Write Multiple commands are disabled, the Write Multiple operation will be rejected with an aborted command error.

Errors encountered during Write Multiple commands are posted after the attempted writes of the block or partial block transferred. The Write command ends with the sector error, even if it is in the middle of a block.

Subsequent blocks are not transferred in the event of an error. Interrupts are generated when DRQ is set at the beginning of each block or partial block.

The Command Block registers contain the cylinder, head and sector number of the sector where the error occurred and the Sector Count register contains the residual number of sectors that need to be transferred for successful completion of the command e.g. each block has 4 sectors, a request for 8 sectors is issued and an error occurs on the third sector. The Sector Count register contains 6 and the address is that of the third sector.

**7.7.41 Write Multiple without Erase – CDH**

Bit →	7	6	5	4	3	2	1	0
<b>Command (7)</b>	CDh							
<b>C/D/H (6)</b>	X	LBA	X	Drive	Head			
<b>Cyl High (5)</b>	Cylinder High							
<b>Cyl Low (4)</b>	Cylinder Low							
<b>Sec Num (3)</b>	Sector Number							
<b>Sec Cnt (2)</b>	X							
<b>Feature (1)</b>	X							

This command is similar to the Write Multiple command with the exception that an implied erase before write operation is not performed. The sectors should be pre-erased with the Erase Sector(s) command before this command is issued.

**7.7.42 Write Sector(s) – 30H or 31H**

Bit →	7	6	5	4	3	2	1	0
<b>Command (7)</b>	30H or 31H							
<b>C/D/H (6)</b>	1	LBA	1	Drive	Head (LBA 27-24)			
<b>Cyl High (5)</b>	Cylinder High (LBA 23-16)							
<b>Cyl Low (4)</b>	Cylinder Low (LBA 15-8)							
<b>Sec Num (3)</b>	Sector Number (LBA 7-0)							
<b>Sec Cnt (2)</b>	X							
<b>Feature (1)</b>	X							

This command writes from 1 to 256 sectors as specified in the Sector Count register. A sector count of zero requests 256 sectors. The transfer begins at the sector specified in the Sector Number register.

When this command is accepted, the CompactFlash card sets BSY, then sets DRQ and clears BSY, then waits for the host to fill the sector buffer with the data to be written. No interrupt is generated to start the first host transfer operation. No data should be transferred by the host until BSY has been cleared by the host first.

For multiple sectors, after the first sector of data is in the buffer, BSY will be set and DRQ will be cleared. After the next buffer is ready for data, BSY is set and DRQ is cleared. It will remain in this state until the command is completed at which time BSY is cleared and an interrupt is generated.

If an error occurs during a write of more than one sector, writing terminates at the sector where the error occurs. The Command Block registers contain the cylinder, head and sector number of the sector where the error occurred. The host may then read the command block to determine what error has occurred, and on what sector.

#### 7.7.43 Write Sector(s) without Erase – 38H

Bit →	7	6	5	4	3	2	1	0
<b>Command (7)</b>	38H							
<b>C/D/H (6)</b>	1	LBA	1	Drive	Head (LBA 27-24)			
<b>Cyl High (5)</b>	Cylinder High (LBA 23-16)							
<b>Cyl Low (4)</b>	Cylinder Low (LBA 15-8)							
<b>Sec Num (3)</b>	Sector Number (LBA 7-0)							
<b>Sec Cnt (2)</b>	X							
<b>Feature (1)</b>	X							

This command is similar to the Write Multiple command with the exception that an implied erase before write operation is not performed. The sectors should be pre-erased with the Erase Sector(s) command before this command is issued.

### 7.7.44 Write Verify – 3CH

Bit →	7	6	5	4	3	2	1	0
<b>Command (7)</b>	3CH							
<b>C/D/H (6)</b>	1	LBA	1	Drive	Head (LBA 27-24)			
<b>Cyl High (5)</b>	Cylinder High (LBA 23-16)							
<b>Cyl Low (4)</b>	Cylinder Low (LBA 15-8)							
<b>Sec Num (3)</b>	Sector Number (LBA 7-0)							
<b>Sec Cnt (2)</b>	X							
<b>Feature (1)</b>	X							

This command is similar to the Write Sector(s) command, except each sector is verified immediately after being written. This command has the same protocol as the Write Sector(s) command.

## 7.8 Error Posting

The following table summarizes the valid status for all the CF-ATA Command set.

### Error and Status Register

Command	Error Register					Status Register				
	BBK	UNC	IDNF	ABRT	AMNF	DRDY	DWF	DSC	CORR	ERR
Check Power Mode				V		V	V	V		V
Execute Drive Diagnostic1						V		V		V
Erase Sector(s)	V		V	V	V	V	V	V		V
Flush Cache				V		V	V	V		V
Format Track			V	V	V	V	V	V		V
Identify Device				V		V	V	V		V
Idle				V		V	V	V		V

Command	Error Register					Status Register				
	BBK	UNC	IDNF	ABRT	AMNF	DRDY	DWF	DSC	CORR	ERR
Idle Immediate				V		V	V	V		V
Initialize Drive Parameters						V		V		V
Key Management Structure Read		V	V	V		V		V		V
Key Management Read Keying Material		V	V	V		V		V		V
Key Management Change Key Management Value		V		V		V	V	V		V
NOP				V		V	V			V
Read Buffer				V		V	V	V		V
Read DMA	V	V	V	V	V	V	V	V	V	V
Read Multiple	V	V	V	V	V	V	V	V	V	V
Read Long Sector	V		V	V	V	V	V	V		V
Read Sector(s)	V	V	V	V	V	V	V	V	V	V
Read Verify Sectors	V	V	V	V	V	V	V	V	V	V
Recalibrate				V		V	V	V		V
Request Sense				V		V		V		V
Security Disable Password				V		V	V	V		V
Security Erase Prepare				V		V	V	V		V
Security Erase Unit				V		V	V	V		V
Security Freeze Lock				V		V	V	V		V

Command	Error Register					Status Register				
	BBK	UNC	IDNF	ABRT	AMNF	DRDY	DWF	DSC	CORR	ERR
Security Set Password				V		V	V	V		V
Security Unlock				V		V	V	V		V
Seek			V	V		V	V	V		V
Set Features				V		V	V	V		V
Set Multiple Mode				V		V	V	V		V
Set Sleep Mode				V		V	V	V		V
Stand By				V		V	V	V		V
Stand By Immediate				V		V	V	V		V
Translate Sector	V		V	V	V	V	V	V		V
Wear Level	V	V	V	V	V	V	V	V		V
Write Buffer				V		V	V	V		V
Write DMA	V		V	V	V	V	V	V		V
Write Long Sector	V		V	V	V	V	V	V		V
Write Multiple	V		V	V	V	V	V	V		V
Write Multiple w/o Erase	V		V	V	V	V	V	V		V
Write Sector(s)	V		V	V	V	V	V	V		V
Write Sector(s) w/o Erase	V		V	V	V	V	V	V		V
Write Verify	V		V	V	V	V	V	V		V
Invalid Command Code				V		V	V	V		V

**Note:** V = Valid on this command

## 8.0 Comparing CF-ATA to PC Card-ATA and True IDE

This section details the differences between CF-ATA when compared to the *PC Card-ATA* and *True IDE*.

### 8.1 Electrical Differences

#### 8.1.1 TTL Compatibility

CF is not TTL compatible, it is a purely CMOS interface. Refer to Electrical Specification section covered earlier in this document.

#### 8.1.2 Pull Up Resistor Input Leakage Current

The minimum pull up input leakage current is 50K ohms rather than the 10K ohms stated in the PCMCIA specification.

### 8.2 Functional Differences

#### 8.2.1 Additional Set Features Codes in CF-ATA

The following *Set Features* codes provide additional functionality in CF-ATA, but are not standard in PC Card-ATA or True IDE:

1. 69H, Accepted for backward compatibility
2. 96H, Accepted for backward compatibility
3. 97H, Accepted for backward compatibility
4. 9AH, Set the host current source capability

#### 8.2.2 Additional Commands in CF-ATA

The following commands provide additional functionality in CF-ATA, but are not standard PC Card-ATA commands.

PC Card-ATA and True IDE define the following command codes as *vendor unique*:

1. C0H, Erase Sectors
2. 87H, Translate Sector
3. F5H, Wear Level

PC Card-ATA and True IDE define the following command codes as *reserved*:

1. 03H, Request Sense
2. 38H, Write Without Erase
3. CDH, Write Multiple Without Erase

### **8.2.3 Idle Timer**

The CF-ATA Idle timer uses an increment value of 5 ms, rather than the 5 second minimum increment value specified in PC Card-ATA/True IDE.

### **8.2.4 Recovery from Sleep Mode**

For CF devices, recovery from sleep mode is accomplished by issuing another command to the device. A hardware or software reset is not required.