

DELKIN DEVICES®

CFast™ Embedded Flash Module

Engineering Specification

Document Number: L50025

Revision: D



No part of this document may be reproduced, copied, recorded, stored in a retrieval system, or transmitted in any form without the written permission of Delkin Devices. This document is for informational use only and is subject to change without prior notice. Delkin Devices assumes no responsibility for any errors that may appear in this document.

Table of Contents

1	General Specifications	3
1.1	Interfaces	5
1.1.1	Electrical / Physical Interfaces	5
1.1.2	Controller Features	5
1.2	Part Number Availability	6
2	Endurance	7
3	Electrical Specifications	8
3.1	Pin and Signal Assignments	8
3.2	Host Write Protection Schematic.....	9
3.3	Supply Voltage	9
3.4	Power Consumption.....	9
4	Command Descriptions	10
4.1	Supported ATA Commands	10
4.2	Identity Device Data	12
4.3	Device SMART Data	16
4.4	Mechanical Form Factor	18
4.5	Physical Dimensions	19

List of Figures

Figure 1.	CFast Embedded Flash Controller Block Diagram	5
Figure 2.	Schematic for Implementation of Write Protect on Enabled Devices	9
Figure 3.	CFast Embedded Module Mechanical Description	18
Figure 4.	CFast Embedded Module Mechanical Dimensions	19

List of Tables

Table 1.	Specification Summary	3
Table 2.	Delkin CFast Embedded Module Capacities and Part Numbers.....	6
Table 3.	Endurance Estimates by Part Number	7
Table 4.	Power and Signal Pin-out.....	8
Table 5.	Supply Voltage	9
Table 6.	Power Consumption.....	9
Table 7.	Supported ATA Commands	10
Table 8.	Device Sector Data	12
Table 9.	Smart Feature Register Values.....	12
Table 10.	Smart Data Structure.....	17
Table 11.	CFast Embedded Module Physical Dimensions	199

1 General Specifications

Delkin's CFast embedded drive combines solid state reliability in a compact form factor with SATA connectivity for significant performance advantages over traditional hard disk drives. Manufactured to CFast form factor specifications established by the CompactFlash Association, the CFast embedded Module is suited to embedded industrial applications where space is restricted. Its shock, vibration, and temperature ratings permit application in extreme environments. The drives can achieve sustained read/write rates of up to 125/95MB/s and feature storage capacities from 2GB to 128GB. Delkin's CFast cards are also available in a special configuration that allows the cards to be put in a write protected state.

Table 1. Specification Summary

Specification	Value
Model number	See Table 2
Capacity	SLC: 2GB – 64GB MLC: 8GB – 128GB
Interface	SATA revision 2.6, compatible with SATA 1.5Gb/s and 3.0Gb/s interface rates. Flash I/O: 3.3V for Asynchronous Flash
Form Factor	CFAST Type I
Hot swappable	Yes
Environmental certifications	RoHS, ESD, and CE/FCC
Performance	
Interface burst speed	1.5 or 3.0 Gb/s
Sustained read	SLC: Up to 125MB/s MLC: Up to 115MB/s
Sustained write	SLC: Up to 95MB/s MLC: Up to 40MB/s
Reliability/Data Integrity	
MTBF	>100,000 power on hours
Data reliability	1 in 10 ¹⁴ bits, read
Endurance	See table in Section
Power	
Supply voltage (allowable)	3.3V ±10%
Typical current (configuration dependent):	
Idle	240 mA
Read	430 mA
Write	460 mA

Environmental	
Storage temperature (°C)	-50 ~ 100°C
Operating temperature options (°C):	
• MLC Commercial	0 ~ 70°C
• MLC Industrial	-40 ~ 85°C
• SLC Commercial	0 ~ 70°C
• SLC Industrial	-40 ~ 85°C
Relative humidity (non-condensing)	95% under 55°C
Vibration (operating/non-operating)	20G (80 – 2000 Hz)
Shock (operating/non-operating)	1,500G/0.5 ms
Acoustic noise	0 dB
Altitude	80,000 feet max.
Physical Dimensions	
Height	3.6 mm
Width	42.8 mm
Length	36.4 mm

1.1 Interfaces

Figure 1 below provides a functional block diagram showing the interaction of CFast embedded MODULE components.

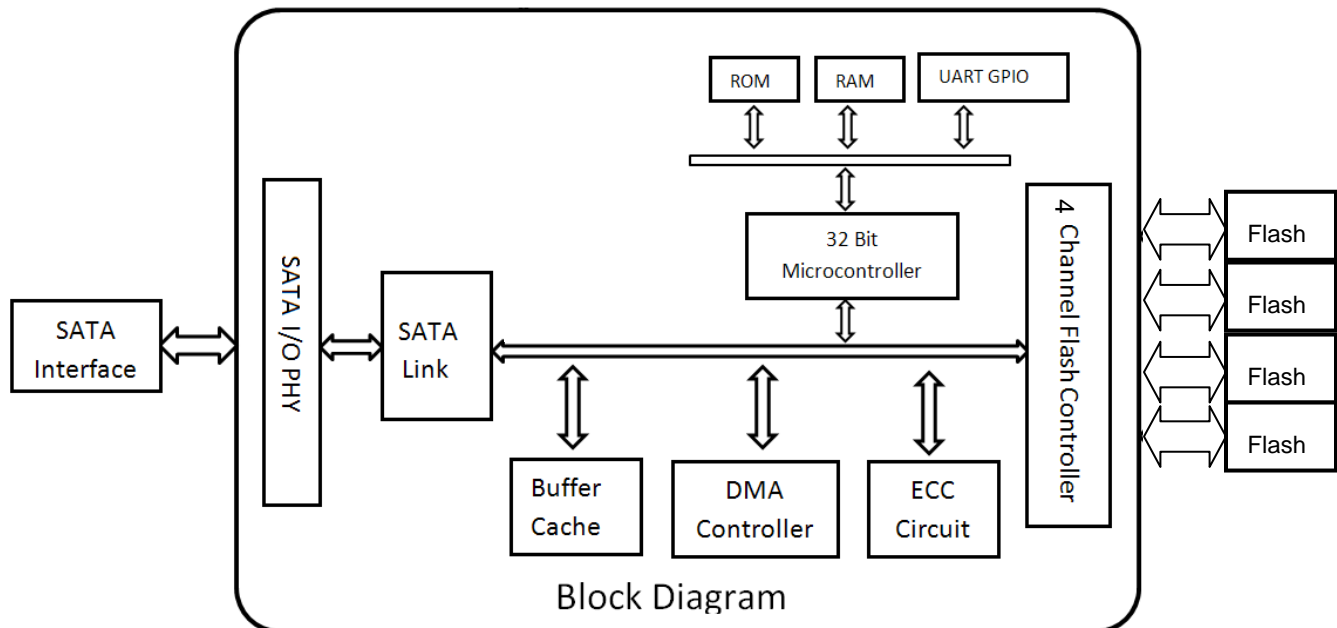

Figure 1. CFast Embedded Flash Controller Block Diagram

1.1.1 Electrical / Physical Interfaces

- SATA Interface—supports SATA 1.5Gbps and 3Gbps interface
- Flash IO—Asynchronous Flash (3.3V)

1.1.2 Controller Features

- **SATA II**
 - SATA Revision 2.6 compliant
 - Compatible with SATA 1.5Gbps and 3Gbps interface

1.2 Part Number Availability

Delkin CFast embedded Solid State Drives are available in the capacities shown in the table below. Drives are also available that feature Delkin's Tekta™ infusion process for greater protection in extreme environments.

Table 2. Delkin CFast Embedded Module Capacities and Part Numbers

Capacity	Product Type	Standard Part Number	Part Number w/ Write-Protect
2GB	SLC Commercial (0 to 70 °C)	BB02TFLTK-XN000-D	BB02TFLV8-WP000-D
	SLC Industrial (-40 to 85 °C)	BE02TFLTQ-XN000-D	BE02TFLV9-WP000-D
4GB	SLC Commercial (0 to 70 °C)	BB04TFHTK-XN000-D	BB04TFHV8-WP000-D
	SLC Industrial (-40 to 85 °C)	BE04TFHTQ-XN000-D	BE04TFHV9-WP000-D
8GB	MLC Commercial (0 to 70 °C)	BA08NFWTK-XN000-D	BA08NFWV8-WP000-D
	MLC Industrial (-40 to 85 °C)	BE08NHUTQ-XN000-D	BE08NHUV9-WP000-D
	SLC Commercial (0 to 70 °C)	BB08TFNTK-XN000-D	BB08TFNV8-WP000-D
	SLC Industrial (-40 to 85 °C)	BE08TFNTQ-XN000-D	BE08TFNTV9-WP000-D
16GB	MLC Commercial (0 to 70 °C)	BA16NFXTK-XN000-D	BA16NFXV8-WP000-D
	MLC Industrial (-40 to 85 °C)	BE16NGTTQ-XN000-D	BE16NGTV9-WP000-D
	SLC Commercial (0 to 70 °C)	BB16TFPTK-XN000-D	BB16TFPV8-WP000-D
	SLC Industrial (-40 to 85 °C)	BE16TFPTQ-XN000-D	BE16TFPV9-WP000-D
32GB	MLC Commercial (0 to 70 °C)	BA32NFFTK-XN000-D	BA32NFFV8-WP000-D
	MLC Industrial (-40 to 85 °C)	BE32NKBTQ-XN000-D	BE32NKBV9-WP000-D
	SLC Commercial (0 to 70 °C)	BB32MGGTK-XN000-D	BB32MGGV8-WP000-D
	SLC Industrial (-40 to 85 °C)	BE32MGGTQ-XN000-D	BE32MGGV9-WP000-D
64GB	MLC Commercial (0 to 70 °C)	BA64NHETK-XN000-D	BA64NHEV8-WP000-D
	MLC Industrial (-40 to 85 °C)	BE64NKOTQ-XN000-D	BE64NKOV9-WP000-D
	SLC Commercial (0 to 70 °C)	BB64MGMTK-XN000-D	BB64MGMV8-WP000-D
	SLC Industrial (-40 to 85 °C)	BE64MGMTQ-XN000-D	BE64MGMV9-WP000-D
128GB	MLC Commercial (0 to 70 °C)	BA1HNHDTK-XN000-D	BA1HNHDV8-WP000-D
	MLC Industrial (-40 to 85 °C)	BE1HNKCTQ-XN000-D	BE1HNKCV9-XN000-D

*Note: Usable capacities are within 10% of the gross capacity figures shown above, which is typical with all NAND flash devices, as a small portion of the total is needed for controller firmware and spare block reserves.

2 Endurance

Endurance

The table below provides estimates of drive endurance (expressed as Terabytes Written or TBW, or Gigabytes Written or GBW) based on specific workload scenarios, using a theoretical model that takes into account the specific flash specifications in each drive configuration. Contact Delkin for endurance estimates for other specific workload scenarios.

Table 3. Endurance Estimates by Part Number

Part Number(s)		Description	Sequential Write Size, 24/7 Operation	
			1000 Bytes/Sec	5000 Bytes/Sec
BB02TFLTK-XN000-D BE02TFLTQ-XN000-D	BB02TFLV8-WP000-D BE02TFLV9-WP000-D	2GB SLC, Commercial or Industrial Grade	6 TBW	10 TBW
			4 TBW	6 TBW
BB04TFHTK-XN000-D BE04TFHTQ-XN000-D	BB04TFHV8-WP000-D BE04TFHV9-WP000-D	4GB SLC, Commercial or Industrial Grade	13 TBW	19 TBW
			7 TBW	11 TBW
BB08TFNTK-XN000-D BE08TFNTQ-XN000-D	BB08TFNV8-WP000-D BE08TFNV9-WP000-D	8GB SLC, Commercial or Industrial Grade	23 TBW	37 TBW
			14 TBW	22 TBW
BB16TFPTK-XN000-D BE16TFPTQ-XN000-D	BB16TFPV8-WP000-D BE16TFPV9-WP000-D	16GB SLC, Commercial or Industrial Grade	16 TBW	36 TBW
BB32MGGTK-XN000-D BE32MGGTQ-XN000-D	BB32MGGV8-WP000-D BE32MGGV9-WP000-D	32GB SLC, Commercial or Industrial Grade	17 TBW	72 TBW
BB64MGMTK-XN000-D BE64MGMTQ-XN000-D	BB64MGMV8-WP000-D BE64MGMV9-WP000-D	64GB SLC, Commercial or Industrial Grade	33 TBW	133 TBW
BA08NFWTK-XN000-D	BA08NFWV8-WP000-D	8GB MLC, Commercial Grade	< 1 TBW	< 1 TBW
BA16NFXTK-XN000-D	BA16NFXV8-WP000-D	16GB MLC, Commercial Grade	2 TBW	6 TBW
BA32NFFTK-XN000-D	BA32NFFV8-WP000-D	32GB MLC, Commercial Grade	< 1 TBW	3 TBW
BA64NHETK-XN000-D	BA64NHEV8-WP000-D	64GB MLC, Commercial Grade	1 TBW	6 TBW
BAH1NHDTK-XN000-D	BA1HNHDV8-WP000-D	128GB MLC, Commercial Grade	3 TBW	12 TBW

The figures provided are estimates and not guarantees of endurance. Actual results may vary depending on usage, operating temperature and other conditions.

3 Electrical Specifications

3.1 Pin and Signal Assignments

Table 4. Power and Signal Pin-out

Pin #	CFAST	Description
S1	SGND	Signal Ground
S2	A+	SATA PAIR A
S3	A-	
S4	SGND	Digital GND
S5	B-	SATA PAIR B
S6	B+	
S7	SGND	Signal Ground
Key		
Key		
PC1	CDI	Card Detect In
PC2	GND	Ground
PC3	NC	No Connect
PC4	NC	No Connect
PC5	NC	No Connect
PC6	NC	No Connect
PC7	GND	Ground
PC8	LED1	LED Output
PC9	LED2	LED Output
PC10	IO1	Reserved (Write Protect, if enabled)
PC11	IO2	Reserved
PC112	IO3	Reserved
PC13	3.3V	Power
PC14	3.3V	Power
PC15	GND	Ground
PC16	GND	Ground
PC17	CDO	Card Detect Out

3.2 Host Write Protection Schematic

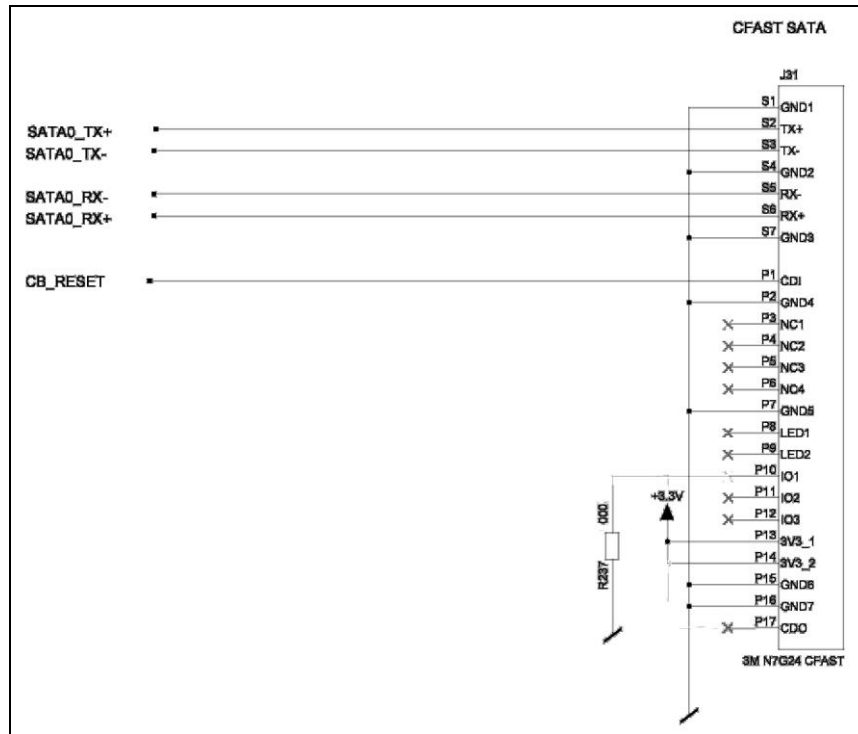

Figure 2. Schematic for Implementation of Write Protection on Enabled Devices

Note: CFast cards must have write protection capability in order to enable write protection feature. For list of part numbers with write protection capability, refer to Table 2 on page 6.

3.3 Supply Voltage

Table 5. Supply Voltage

Parameter	Rating
Operating Voltage	3.3V

3.4 Power Consumption

Table 6. Power Consumption

Parameter	Value (mA)
Idle	240
Read	430
Write	460

Note: Values based on 128GB (256Gbit MLC x4) statistics, values may vary by capacity and flash type.

4 Command Descriptions

4.1 Supported ATA Commands

The commands listed in the following table are supported by the CFast embedded MODULE.

Table 7. Supported ATA Commands

Command Name	Command Code (Hex)	Command Name	Command Code (Hex)
General Feature Set			
Execute Drive Diagnostic	90h	Flush Cache	E7h
Identify Device	ECh	Read DMA	C8h
Read Multiple	C4h	Read Sector(s)	20h
Read Verify Sector(s)	40h	Set Feature	EFh
Set Multiple Mode	CAh	Write Multiple	C5h
Write Sector(s)	30h	NOP	00h
Read Buffer	E4h	Write Buffer	E8h
Power Management			
Check Power Mode	E5h or 98h	Idle	E3h or 97h
Sleep	E6h or 99h	Standby	E2h or 96h
Standby Immediate	E0h or 94h		
Security			
Security Set Password	F1h	Security Unlock	F2h
Security Erase Prepare	F3h	Security Erase Unit	F4h
Security Freeze Lock	F5h	Security Disable Password	F6h
SMART Feature Set			
SMART Disable Operations	B0h	SMART Enable/Disable Autosave	B0h
30 SMART Enable Operations	B0h	SMART Return Status	B0h
SMART Execute Off-Line Immediate	B0h	SMART Read Data	B0h
Host Protected Area			
Read Native Max Address	F8h	Set Max Address	F9h
Set Max Set Password	F9h	Set Max Lock	F9h
Set Max Freeze Lock	F9h	Set Max Unlock	F9h

48-Bit address Feature Set			
Flush Cache Ext	Eah	Read Sector(s) Ext	24h
Read DMA Ext	25h	Read Multiple Ext	29h
Read Native Max Address Ext	27h	Read Verify Sector(s) Ext	42h
Set Max Address Ext	37h	Write DMA Ext	35h
Write DMA FUA Ext	3Dh	Write Multiple Ext	39h
Write Multiple FUA Ext	CEh	Write Sector(s) Ext	34h

4.2 Identity Device Data

The following table details the sector data returned by the `IDENTIFY DEVICE` command.

Table 8. Device Sector Data

Word	F: Fixed V: Variable X: Both	Default Value	Description
0	F	045Ah	General configuration bit-significant information
1	X	3FFFh	Obsolete - Number of logical cylinders(16383)
2	V	0000h	Specific configuration
3	X	0010h	Obsolete - Number of logical heads (16)
4-5	X	02007E00h	Retired
6	X	003Fh	Obsolete - Number of logical sectors per logical track (63)
7-8	V	0h	Reserved for assignment by the Compact Flash Association
9	X	0h	Retired
10-19	F	Varies	Serial number (20 ASCII characters)
20-21	X	0h	Retired
22	X	0h	Obsolete
23-26	F	Varies	Firmware revision (8 ASCII characters)
27-46	F	Varies	Model number
47	F	8001h	7:0 - Maximum number of sectors transferred per interrupt on MULTIPLE commands.
48	F	0h	Reserved
49	F	0F00h	Capabilities
50	F	4000h	Capabilities
51-52	X	00000200h	Obsoleted
53	F	0007h	Words 88 and 70:64 valid
54	X	3FFFh	Obsolete - Number of logical cylinders (16383)
55	X	0010h	Obsolete - Number of logical heads (16)
56	X	003Fh	Obsolete - Number of logical sectors per track (63)
57-58	X	00FBFC10h	Obsolete

Word	F: Fixed V: Variable X: Both	Default Value	Description
59	F	0100h	Number of sectors transferred per interrupt on MULTIPLE commands
60-61	F	Varies by Card Capacity	Total number of user addressable sectors
62	X	0h	Obsolete
63	F	0007h	Multi-word DMA modes supported/selected
64	F	0003h	PIO modes supported
65	F	0078h	Minimum Multiword DMA transfer cycle time per word
66	F	0078h	Manufacturer's recommended Multiword DMA transfer cycle time
67	F	0078h	Minimum PIO transfer cycle time without flow control
68	F	0078h	Minimum PIO transfer cycle time with IORDY flow control
69-70	F	0h	Reserved
71-74	F	0h	Reserved for the IDENTIFY PACKET DEVICE command
75	F	0h	Queue depth
76	F	0002h	Serial SATA capabilities
77	F	0h	Reserved for future Serial ATA definition
78	F	0000h	Serial ATA features supported
79	V	0000H	Serial ATA features enabled
80	F	00F8h	Major Version Number
81	F	0021h	Minor Version Number
82	F	7429h	Command set supported
83	F	7008h	Command set supported
84	F	4000h	Command set/feature supported extension
85	V	7028h	Command set/feature enabled
86	V	3000h	Command set/feature enabled
87	V	4000h	Command set/feature default
88	V	007Fh	Ultra DMA Modes
89	F	0000h	Time required for security erase unit com

Word	F: Fixed V: Variable X: Both	Default Value	Description
90	F	0000h	Time required for Enhanced security erase completion
91	V	0h	Current advanced power management value
92	V	0000h	Master Password Revision Code
93	F	0h	Hardware reset result. The contents of the bits (12:0) of this word shall change only during the execution of a hardware reset.
94	V	0h	Vendor's recommended and actual acoustic management value
95	F	0h	Stream Minimum Request Size
96	V	0h	Streaming Transfer Time - DMA
97	V	0h	Streaming Access Latency - DMA and PIO
98-99	F	0h	Streaming Performance Granularity
100-103	V	Not Applicable	Maximum user LBA for 48-bit Address feature set
104	V	0h	Streaming Transfer Time - PIO
105	F	0h	Reserved
106	F	0h	Physical sector size/Logical sector size
107	F	0h	Inter-seek delay for ISO-7779 acoustic testing in microseconds
108-111	F	0h	Unique ID
112-115	F	0h	Reserved
116	V	0h	Reserved
117-118	F	0h	Words per logical Sector
119	F	0h	Supported settings
120	F	0h	Command set/Feature Enabled/Supported
121-126	F	0h	Reserved
127	F	0h	Removable Media Status Notification feature set support
128	V	0h	Security status

Word	F: Fixed V: Variable X: Both	Default Value	Description
129-159	X	0h	Vendor specific
160	F	0h	Compact Flash Association (CFA) power mode 1
161-175	X	0h	Reserved for assignment by the CFA
176-205	V	0h	Current media serial number
206-216	F	0h	Reserved
217	F	0h	Non-rotating media device
218-221	F	0h	Reserved
222	F	0h	Reserved
223-233	F	0h	Reserved
234	F	0h	Reserved
235	F	0h	Reserved
236-255	F	0h	Reserved
255	X	Varies	Integrity word (Checksum and Signature)

4.3 SMART Command Support

The Delkin Industrial CFast cards feature Self-Monitoring, Analysis and Reporting Technology (SMART). Enabled by readily-available software utilities, SMART can monitor online storage devices for failure prediction, status reporting, and bad sector detection and repair. SMART can protect against system downtime and prevent data loss.

4.3.1 SMART Register Values

In order to select a subcommand, the host must write the subcommand code to the device's Features Register before issuing the SMART Function Set command. The subcommands are listed below:

Table 9. SMART Feature Register Values

Value	Subcommand	Description
D0h	READ DATA	Retrieves SMART information from the device, which is packed into the data structure as defined in Section 4.3.2
D1h	READ ATTRIBUTE THRESHOLD	This command is obsolete as of ATA-4 and later versions, but is maintained for backward compatibility.
D2h	ENABLE/DISABLE AUTOSAVE	Enables / disables optional attribute auto-save feature, however, the auto-save feature is always enabled.
D3h	SAVE ATTRIBUTE VALUES	This command is obsolete as of ATA-6 and later versions, but is maintained for backward compatibility. Attribute values are saved automatically.
D4h	EXECUTE OFF-LINE IMMEDIATE	This command initiates activities that collect SMART data or execute self-diagnostic test routines in an off-line mode or captive mode, however there are currently no self-test or off-line data collection capabilities.
D5h	RESERVED	
D6h	RESERVED	
D8h	ENABLE SMART OPERATIONS	This command enables access to all SMART command operations.
D9h	DISABLE SMART OPERATIONS	This command disables access to all SMART command operations.
DAh	RETURN STATUS	This command returns the reliability status of the device to the host. This reliability status is determined by comparing the number of available spare blocks to the minimum spare block threshold.

If the reserved size is below the threshold, the status can be read from the Cylinder Register using the Return Status command (DAh.) Please note that D1h and D3h are obsolete commands according to ATA-7, but are still provided to maintain backward compatibility with previous ATA specifications.

4.3.2 SMART Data Structure

The following 512 bytes make up the device SMART data structure. Users can obtain the data using the “Read Data” command (D0h).

Table 10. SMART Data Structure

Word	F: Fixed V: Variable X: Both	Description
0 - 1	X	Revision code
2 – 361	X	Vendor specific
362	V	Off-line data collection status
363	X	Self-test execution status byte
364 - 365	V	Total time in seconds to complete off-line data collection activity
366	X	Vendor specific
367	F	Off-line data collection capability
368 – 369	F	SMART capability
370	F	Error logging capability
371	X	Vendor specific
372	F	Short self-test routine recommended polling time (in minutes)
373	F	Extended self-test routine recommended polling time (in minutes)
374	F	Conveyance self-test routine recommended polling time (in minutes)
375 - 385	R	Reserved
386 - 395	F	Firmware Version/Date Code
396 - 397	F	Number of initial invalid block (396 = MSB, 397 = LSB)
398 - 399	V	Number of run time bad block (398 = MSB, 399 = LSB)
400 - 406	F	
407 - 415	X	Vendor specific
416	F	Reserved

4.4 Mechanical Form Factor

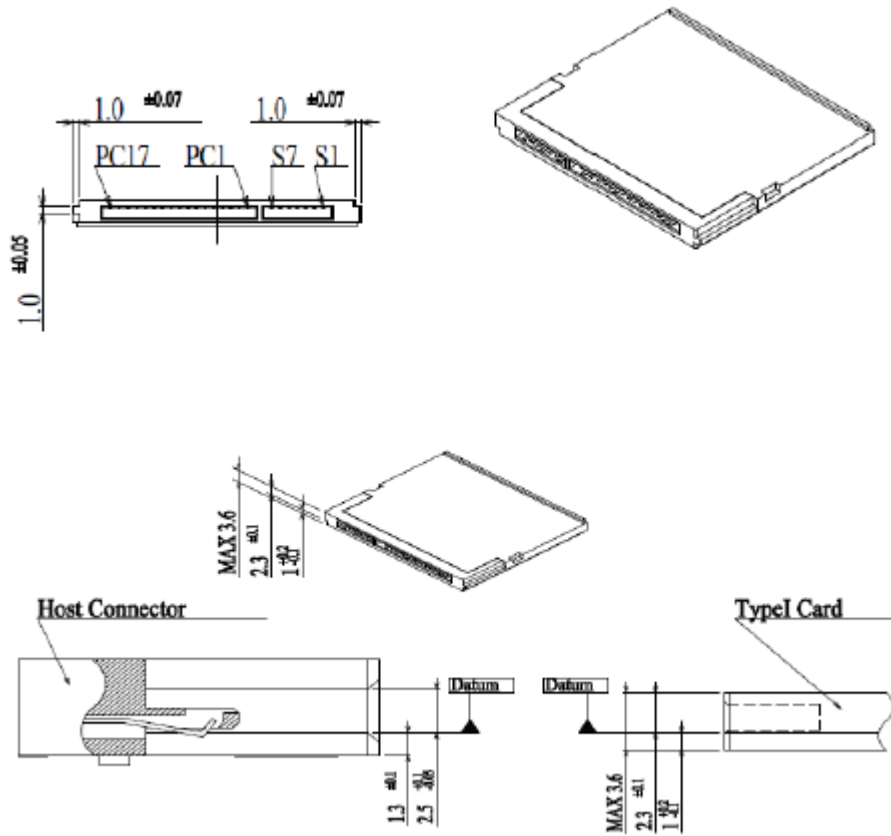

Figure 3. CFast Embedded Module Mechanical Description

4.5 Physical Dimensions

Table 11. CFast Embedded Module Physical Dimensions

Dimension	Measurement
Height	3.6mm
Width	42.8mm
Length	36.4mm

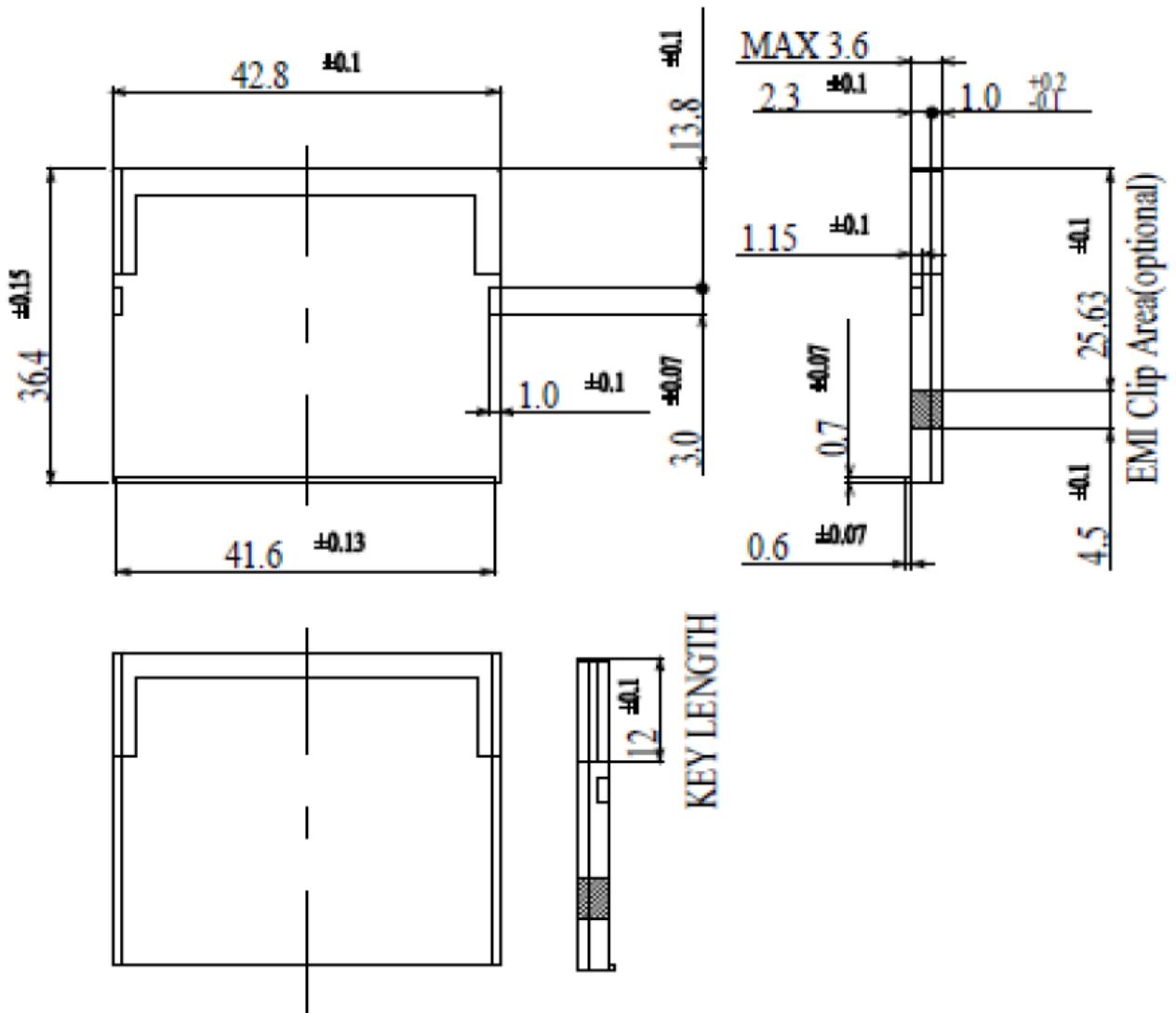

Figure 4. CFast Embedded Module Mechanical Dimensions