

DELKIN DEVICES®

B270 Series USB Flash Drive Engineering Specification

Document Number: L5ENG00242

Revision: D



Table of Contents

1.0	General Description.....	3
1.1	Recommended Temperature Conditions	4
1.2	Performance.....	4
1.3	Environmental Characteristics	4
1.4	Reliability.....	4
1.5	Dimensions.....	5
1.6	Part Numbers	6
2.0	Electrical Characteristics	7
2.1	Absolute Maximum Ratings	7
2.2	DC Characteristics	8

List of Figures

Figure 1. Dimensions	5
----------------------------	---

List of Tables

Table 1. Dimensions.....	5
Table 2. Absolute Maximum Ratings.....	7
Table 3. Operating Parameters	7
Table 4. Characteristics.....	8

1.0 General Description

The Delkin USB Flash Drive is a convenient and reliable data storage option for industrial applications, available in two product grades: SLC Industrial and MLC Commercial. With USB 2.0 and up to 32 GB of available storage, the Delkin USB 2.0 Flash Drive delivers the capacity you need in a mechanically robust package. It works with all newer PC's with an existing USB 1.1 or USB 2.0 port (see compatibility below).

Features

- Available in the following capacities:
 - SLC – 128MB, 256MB, 512MB, 1GB, 2GB, 4GB, 8GB, 16 GB, 32GB
 - MLC – 2GB, 4GB (others available upon request)
- High-speed USB 2.0 certified (backwards compatible with all USB 1.1 ports)
- Static and dynamic wear-leveling
- Completes USB specification ver.2.0 compatibility
- Complies with USB Mass Storage Class specification ver. 1.0
- Supports MLC and SLC Flash Memory with 8- and 15-bits/528B ECC

Supported Operating Systems

USB flash operates as a removable disk drive via a USB connector.

Compatible with the following operating systems:

1. Windows 7/ Vista / XP/ 2000 / ME / 98SE
2. Linux Kernel 2.4 and above
3. Mac OS 9.x and above

Reliability

Data Retention

- | | |
|------|---|
| SLC: | 10 years when <10% of P/E cycles consumed |
| | 1 year when 100% of P/E cycles have been consumed |
| MLC: | 5 years when <10% of P/E cycles consumed |
| | 1 year when 100% of P/E cycles have been consumed |

1.1 Recommended Temperature Conditions

Parameter	Temperature Range Min ~ Max
Storage Temperature	-50°C ~ 85°C
Operating Temperature	SLC Industrial: -40°C ~ 85°C MLC Commercial: 0°C ~ 70°C

1.2 Performance

Parameter	Value
“High Speed” Transfer Rate	Up to 480 Mbits/sec for USB 2.0
“Full Speed” Transfer Rate	Up to 12 Mbits/sec

1.3 Environmental Characteristics

Parameter	Value
Shock	10g's for 11ms
Vibration	15Hz to 2000Hz
Humidity	5% to 95% Non-condensing
Altitude	80,000 feet

1.4 Reliability

Parameter	Value
Cycle Endurance	SLC – raw flash rated for 60,000 P/E cycles MLC – raw flash rated for 3,000 P/E cycles Actual write cycles dependent on usage model.
MTBF***	>2,000,000 hours @ 0 - 25 °C
Data Retention	SLC – 10 years @ 10% / 1 year @ 100% of P/E cycles MLC – 5 years @ 10% / 1 year @ 100% of P/E cycles

*** Dependent on configuration and testing environment

1.5 Dimensions for Standard & Short Length Options

Table 1. Dimensions

Dimension	Measurement
Height	8.00mm ± 0.10mm
Width	17.00mm ± 0.20mm
Total Length	Standard: 67.70mm ± 1.00mm Short: 57.60mm ± 1.00mm
Length excluding Cap	Standard: 66.34mm ± 1.00mm Short: 54.80mm ± 1.00mm

Figure 1. Dimensions

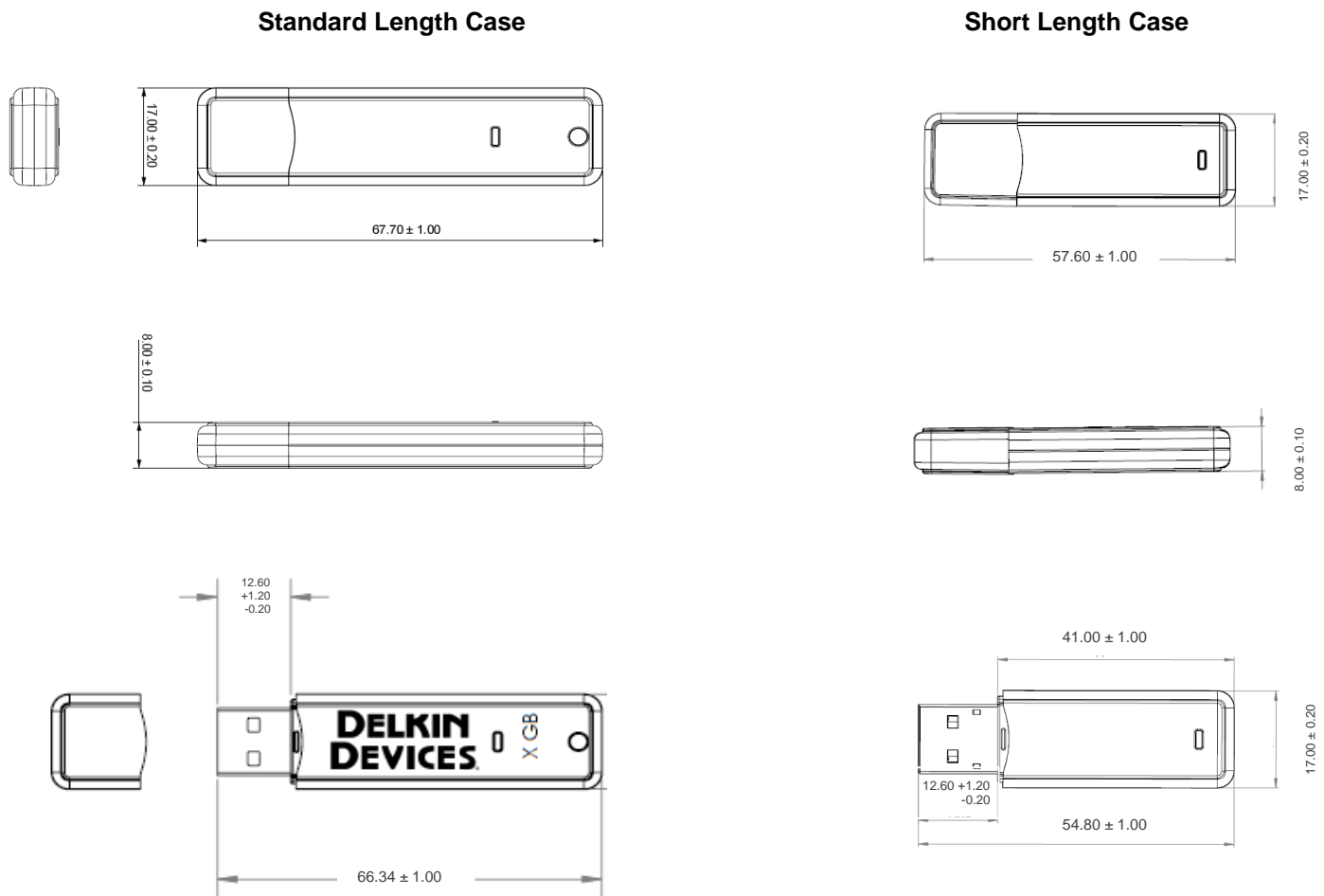

1.6 Part Numbers

Capacity*	SLC Industrial Grade (-40 to 85 °C)	
	Standard Length Case	Short Length Case
128MB	UY12TFJSY-XN000-D	UY12TFJSY-SN000-D
256MB	UY25TFKSY-XN000-D	UY25TFKSY-SN000-D
512MB	UY51TFKSY-XN000-D	UY51TFKSY-SN000-D
1GB	UY0GTFLSY-XN000-D	UY0GTFLSY-SN000-D
2GB	UY02TFHSY-XN000-D	UY02TFHSY-SN000-D
4GB	UY04TFNSY-XN000-D	UY04TFNSY-SN000-D
8GB	UY08TFPSY-XN000-D UY08MGGVS-XN000-D	UY08TFPSY-SN000-D UY08MGGVS-SN000-D
16GB	UY16MGGVS-XN000-D	UY16MGGVS-SN000-D
32GB	UY32MGMVS-XN000-D	UY32MGMVS-SN000-D

Capacity*	MLC Commercial Grade (0 to 70 °C)	
	Standard Length Case	Short Length Case
2GB	US02NFWV6-XN000-D	US02NFWV6-SN000-D
4GB	US04NFWV6-XN000-D	US04NFWV6-SN000-D

*Note: Usable capacities are within 10% of the gross capacity figures shown above, which is typical with all NAND flash devices, as a small portion of the total is needed for controller firmware and spare block reserves.

Part Numbers above are for standard dark blue case with pad printed Delkin Devices logo. For other options, including additional Pantone case colors, custom logo pad printing, serialization, etc., please contact Delkin for more information.

Other MLC configurations available upon request.

2.0 Electrical Characteristics

2.1 Absolute Maximum Ratings

Stresses in excess of the absolute maximum ratings can cause permanent damage to the device. These are absolute stress ratings only. Functional operation of the device is not implied at these or any other conditions in excess of those given in the operations sections of this data sheet. Exposure to absolute maximum ratings for extended periods can adversely affect device reliability.

Table 2. Absolute Maximum Ratings

Parameter	Symbol	Min	Max	Unit
DC Power Supply	$V_{DD} - V_{SS}$	-0.3	+5.5	V
Input Voltage	V_{IN}	$V_{SS}-0.3$	$V_{DD}+0.3$	V
Operating Temperature (MLC Commercial)	T_a	0	+70	°C
Operating Temperature (SLC Commercial)	T_a	0	+70	°C
Operating Temperature (SLC Industrial)	T_a	-40	+85	°C
Storage Temperature (All Grades)	T_{st}	-50	+85	°C

Table 3. Operating Parameters

Parameter	Symbol	Min	Typ	Max	Unit
Operating Temperature (MLC Commercial)	T_a	0	+25	+70	°C
Operating Temperature (SLC Commercial)	T_a	0	+25	+70	°C
Operating Temperature (SLC Industrial)	T_a	-40	+25	+85	°C
VDD Voltage	VDD	4.5	5.0	5.5	V

2.2 DC Characteristics

Table 4. Characteristics

Parameter	Symbol	Conditions	Min	Typ	Max	Unit
Core Power Supply	VCKK	Core Area	1.62	1.8	1.98	V
Power Supply	VCC3IO	3.3V I/O	3.0	3.3	3.6	V
Junction Temperature	Temp		0	25	115	°C
Switching threshold	Vt	LVTTL		1.5		V
Schmitt Trigger Negative Going threshold voltage	Vt-	LVTTL	0.8	1.1		V
Schmitt Trigger Positive Going threshold voltage	Vt+			1.6	2.0	V
Output Low voltage	Vol	[Iol] = 2 ~ 16mA			0.4	V
Output High voltage	Voh	[Ioh] = 2 ~ 16mA	2.4			V
Input Pull-Up Resistance	Rpu	PU=high, PD=low	40	75	190	KΩ
Input Pull-Down Resistance	Rpd	PU=high, PD=low	40	75	190	KΩ
Input Leakage Current	Iin	Vin = VCC3I or 0			1	μA
Tri-state Output Leakage Current	Ioz		-10	±1	10	μA